

**Modular Cooking Range Line
EVO700 4-Zone Electric Infrared
Cooking Top Range on Electric
Oven**

ITEM # _____

MODEL # _____

NAME # _____

SIS # _____

AIA # _____

**Modular Cooking Range Line****EVO700 4-Zone Electric Infrared
Cooking Top Range on Electric Oven**

372026 (Z7IREH40E0)

4-zone (2,2 kW each) infrared
cooking range on electric
oven (6 kW)**Short Form Specification**

Item No. _____

Ceramic glass top cooking surface 6 mm thick, lying flush to the stainless steel frame for smooth pan movement and easier cleaning. Completely sealed infrared cooking top surface to prevent liquid infiltration. Electric oven with switch to control top and bottom heating elements. Stainless steel oven chamber with 3 levels of runners to accommodate 2/1 GN shelves (2 steam pans) and ribbed oven base plate. Exterior panels in stainless steel with Scotch Brite finish. One piece pressed work top in 1.5 mm thick stainless steel. Right-angled side edges to allow flush-fitting junction between units.

APPROVAL: _____

Main Features

- Ceramic glass top cooking surface with 4 infrared heating zones 6 mm thick.
- The circular concentric heating sections measuring 230 mm give uniform heat also to the largest pan.
- The cooking top is sealed to prevent infiltration inside the unit.
- Warning light to indicate residual surface heat.
- Immediate heat transfer from cooking top to pan.
- Low heat dissipation to the kitchen.
- Energy regulation of each zone.
- Heating via ultra high powered heating elements.
- The smooth glass-ceramic surface can be quickly and easily cleaned, thus providing maximum hygiene.
- Base compartment consists of an electric standard oven with thick oven door for heat insulation, positioned beneath the base plate.
- Stainless steel oven chamber with 3 levels of runners to accommodate 2/1 GN shelves (2 steam pans).
- Oven thermostat adjustable from 140 °C to 300 °C.
- IPX 4 water protection.

Construction

- All exterior panels in Stainless Steel with Scotch Brite finishing.
- One piece pressed 1.5 mm work top in Stainless steel.
- Model has right-angled side edges to allow flush fitting joints between units, eliminating gaps and possible dirt traps.

Included Accessories

- 1 of GN2/1 chrome grid for static oven PNC 164250

Optional Accessories

- GN2/1 chrome grid for static oven PNC 164250
- 4 wheels, 2 swivelling with brake (EVO700/900). It is mandatory to install with base supports for feet/wheels. PNC 206135
- Flanged feet kit PNC 206136
- Frontal kicking strip for concrete installation, 200 mm PNC 206146
- Frontal kicking strip for concrete installation, 400 mm PNC 206147
- Frontal kicking strip for concrete installation, 800 mm PNC 206148
- Frontal kicking strip for concrete installation, 1000 mm PNC 206150
- Frontal kicking strip for concrete installation, 1200 mm PNC 206151
- Frontal kicking strip for concrete installation, 1600 mm PNC 206152
- Frontal handrail 400 mm PNC 206166
- Frontal handrail 800 mm PNC 206167
- Frontal kicking strip, 200 mm PNC 206174
- Frontal kicking strip, 400 mm PNC 206175
- Frontal kicking strip, 800 mm PNC 206176
- Frontal kicking strip, 1000 mm PNC 206177
- Frontal kicking strip, 1200 mm PNC 206178
- Frontal kicking strip, 1600 mm PNC 206179
- Large handrail (portioning shelf) 400 mm PNC 206185
- Large handrail (portioning shelf) 800 mm PNC 206186
- Frontal handrail 1200 mm PNC 206191
- Frontal handrail 1600 mm PNC 206192
- 4 feet for concrete installation (not for 900 line freestanding grill) PNC 206210
- Right and left side handrails PNC 206240
- Pair of side kicking strips PNC 206249
- Pair of side kicking strips (concrete installation) PNC 206265
- Water column with swivel arm (water column extension not included) PNC 206289
- Water column extension PNC 206291
- Chimney upstand, 800 mm PNC 206304
- 2 side covering panels, height 700 mm, depth 700 mm PNC 206319
- Base support for feet or wheels - 800mm (EVO700/900) PNC 206367
- Chimney grid net, 400mm PNC 206400

Front

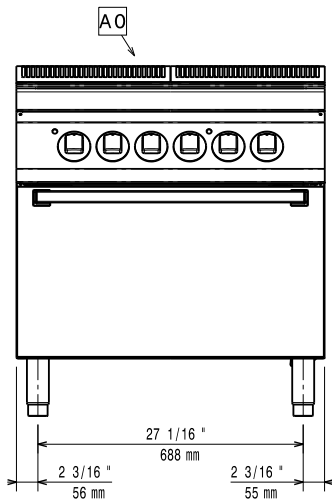

Top

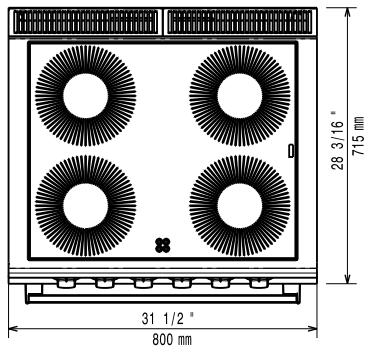

EI = Electrical connection
EQ = Equipotential screw

Side

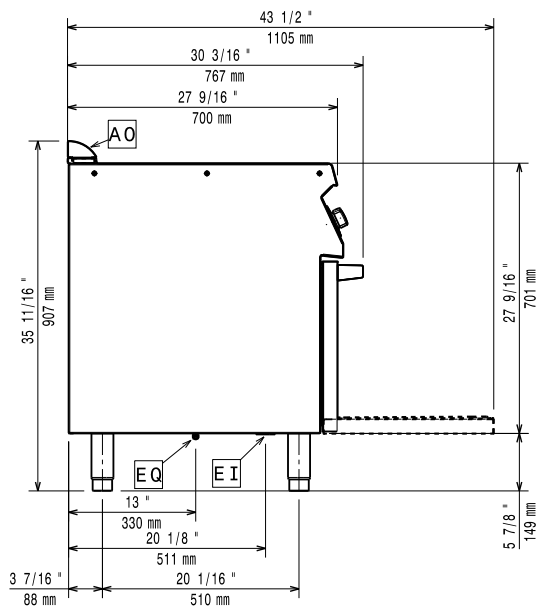

Electric

Supply voltage:

372026 (Z7IREH40E0) 400 V/3N ph/50/60 Hz

Total Watts:

14.8 kW

Key Information:

Front Plates Power:	2.2 - 2.2 kW
Back Plates Power:	2.2 - 2.2 kW
Front Plates dimensions:	Ø 230 Ø 230
Back Plates dimensions:	Ø 230 Ø 230
Oven working Temperature:	140 °C MIN; 300 °C MAX
Oven Cavity Dimensions (width):	540 mm
Oven Cavity Dimensions (height):	300 mm
Oven Cavity Dimensions (depth):	650 mm
Net weight:	85 kg
Shipping weight:	105 kg
Shipping height:	1140 mm
Shipping width:	820 mm
Shipping depth:	860 mm
Shipping volume:	0.8 m ³

If appliance is set up or next to or against temperature sensitive furniture or similar, a safety gap of approximately 150 mm should be maintained or some form of heat insulation fitted.