

RANGE COMPOSITION

EVO700: range comprised of over 100 models designed to guarantee the highest level of performance, reliability, energy saving, safety standards and ergonomic operation. These concepts are reflected throughout the line in its modularity, construction and numerous configurations. Thanks to its advance technology and premium performance, the EVO700 is a perfect solution for institutions with a limited footprint as well as restaurants needing to obtain the most from the kitchen space. The models detailed in this sheet are 6 burners gas ranges on gas or electric oven and base.



372005

EVO700

6 BURNER GAS RANGES **ZANUSSI** PROFESSIONAL

FUNCTIONAL AND CONSTRUCTION FEATURES

- ◆ Burners:
 - 5,5 kW (with continuous flame regulation from 1,1kW to 5,5kW) - Flame failure device to protect against accidental extinguishing of the flame. - Protected pilot light.
 - ◆ Electric oven with switch to control top and bottom heating elements.
 - ◆ Electric oven thermostat with temperature markings in °C adjustable from 140° to 300°C.
 - ◆ Gas oven with stainless steel, tubular, high efficiency, atmospheric burners positioned below the base plate and thermostat adjustable from 110° to 270°C.
 - ◆ Worktop in 1,5mm stainless steel. Front panel in stainless steel with Scotch Brite finish.
 - ◆ Feet in stainless steel adjustable in height 50mm.
 - ◆ Pan supports are in cast iron.

TECHNICAL DATA		
CHARACTERISTICS	MODELS	
	Z7GCGL6C10 372005	Z7GCGL6C20 372006
Power supply	Gas	Gas/Electric
External dimensions - mm		
width	1200	1200
depth	700	700
height	850	850
height adjustment	50	50
Oven cavity - mm		
width	540	540
depth	650	650
height	300	300
Oven		
heat input - kW	6	6
temperature min-max - °C	110, 270	140, 300
Storage cupboard - mm		
width	330	330
depth	640	640
height	380	380
Back burner dimensions - mm	Ø 60, Ø 60, Ø 60	Ø 60, Ø 60, Ø 60
Back burners power - kW	5.5, 5.5, 5.5	5.5, 5.5, 5.5
Front burners dimension - mm	Ø 60, Ø 60, Ø 60	Ø 60, Ø 60, Ø 60
Front burners power - kW	5.5, 5.5, 5.5	5.5, 5.5, 5.5
Power - kW		
gas	39	33
installed-electric		6
Net weight - kg.	120	120
Supply voltage		400 V, 3N, 50/60
INCLUDED ACCESSORIES		
2/1 GN CHROME GRID	1	1
DOOR FOR OPEN BASE CUPBOARD-ZANUSSI	1	1

- ◆ All models have right-angled side edges to allow flush-fitting joints between units eliminating gaps and possible dirt traps.
- ◆ Stainless steel oven chamber with 3 levels of runners to accommodate 2/1GN shelves.
- ◆ The special design of the control knobs and bezels guarantees against water infiltration.
- ◆ IPX4 water protection.
- ◆ Main connections can be via the base of the unit.
- ◆ All gas appliances are supplied for use with natural gas, LPG or town gas. Conversion jets supplied as standard.

OPTIONAL ACCESSORIES		
ACCESSORIES	MODELS	
	Z7GCGL6C10 372005	Z7GCGL6C20 372006
2 SIDE COVERING PANELS H=700-D=700-Z/OEM	206319	206319
2 SIDE KICKING STRIPS - 700 LINE	206249	206249
2 SIDE KICKING STRIPS-CONCRETE INST-700	206265	206265
2 SUPPORTS+RUNNERS- 4 GN 1/1-700 LINE FS	206244	206244
2/1 GN CHROME GRID	164250	164250
4 FEET FOR CONCRETE INSTALLATION	206210	206210
4 WHEELS (2 WITH BRAKE)	206188	206188
CHIMNEY UPSTAND 1200MM	206306	206306
DOOR FOR OPEN BASE CUPBOARD-ZANUSSI	206342	206342
DOUBLE BURNER RIBBED PLATE - 700 LINE	921685	921685
DOUBLE BURNER SMOOTH PLATE - 700 LINE	921684	921684
DRAUGHT DIVERTER WITH 150 MM DIAMETER	206132	206132
ELECTRIC HEATING KIT FOR CUPBOARDS	206259	206259
FLANGED FEET KIT	206136	206136
FLUE CONDENSER FOR 1 MODULE DIAM.150MM	206246	206246
FRONT.KICK.STRIP F.CONCRETE INST.1000 MM	206150	206150
FRONT.KICK.STRIP F.CONCRETE INST.1200 MM	206151	206151
FRONT.KICK.STRIP F.CONCRETE INST.1600 MM	206152	206152
FRONT.KICK.STRIP F.CONCRETE INST.200 MM	206146	206146
FRONT.KICK.STRIP F.CONCRETE INST.400 MM	206147	206147
FRONT.KICK.STRIP F.CONCRETE INST.800 MM	206148	206148
FRONTAL HANDRAIL 1200 MM	206191	206191
FRONTAL HANDRAIL 1600 MM	206192	206192
FRONTAL KICKING STRIP 1000 MM	206177	206177
FRONTAL KICKING STRIP 1200 MM	206178	206178
FRONTAL KICKING STRIP 1600 MM	206179	206179
FRONTAL KICKING STRIP 200 MM	206174	206174
FRONTAL KICKING STRIP 400 MM	206175	206175
FRONTAL KICKING STRIP 800 MM	206176	206176
LARGE HANDRAIL(PORTIONING SHELF)400 MM	206185	206185
LARGE HANDRAIL(PORTIONING SHELF)800 MM	206186	206186
MATCHING RING FOR FLUE CONDENSER 150DIAM	206133	206133
PRESSURE REGULATOR FOR GAS UNITS	927225	
S/S GRID FOR DOUBLE BURNER-700 LINE	206297	206297
SIDE HANDRAIL-RIGHT/LEFT HAND-700 LINE	206240	206240
SINGLE BURNER RADIANT PLATE - 700 LINE	206264	206264
SINGLE BURNER RIBBED PLATE - 700 LINE	206261	206261
SINGLE BURNER SMOOTH PLATE - 700 LINE	206260	206260
WATER COLUMN EXTENSION FOR 700 LINE	206291	206291
WATER COLUMN WITH SWIVEL ARM	206289	206289



www.zanussiprofessional.com

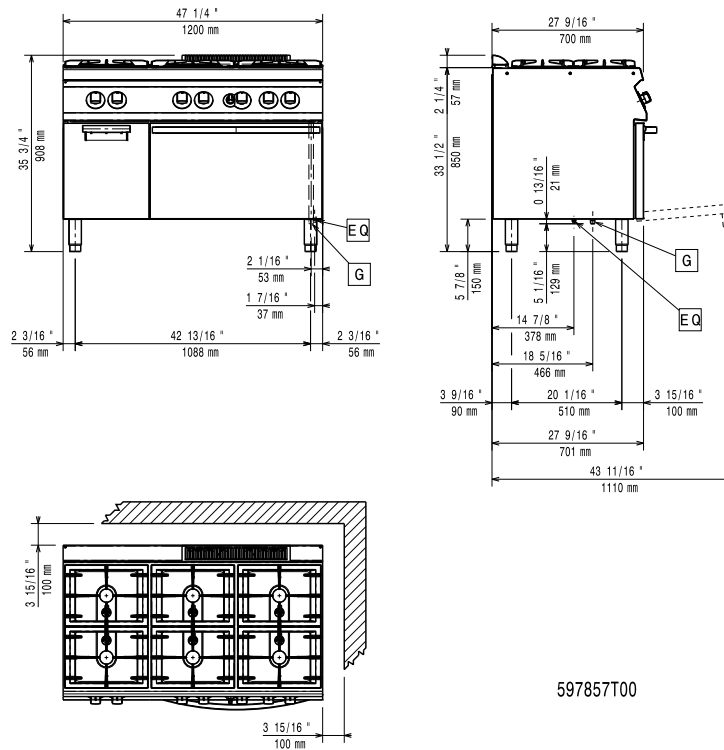

LEGEND

G - Gas connection

Z7GCGL6C10

372005

1/2"



www.zanussiprofessional.com

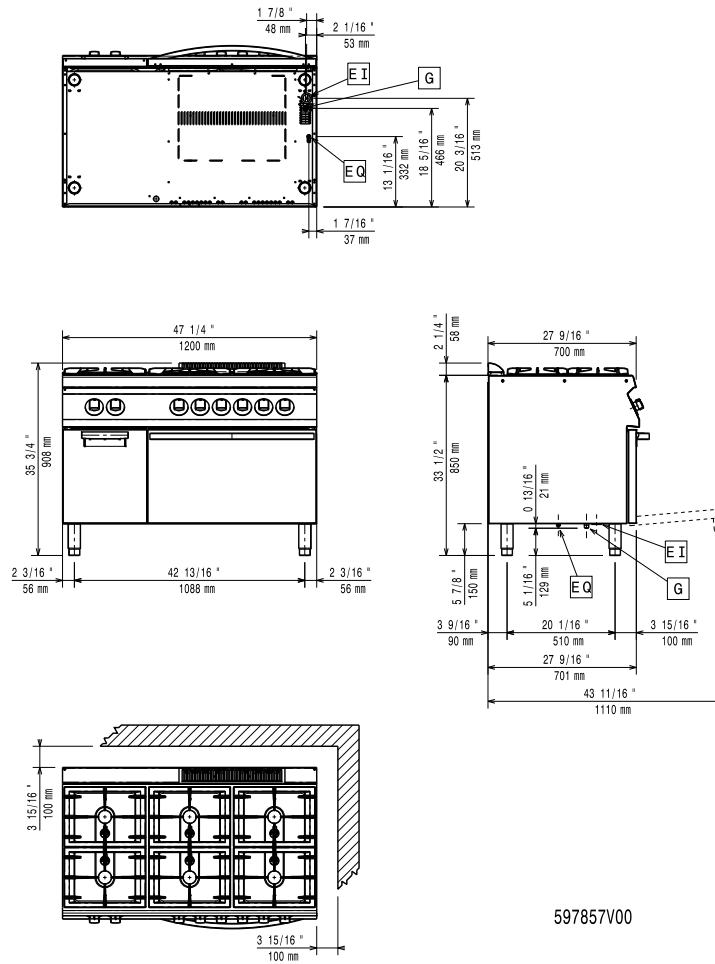

597857V00

LEGEND

	Z7GCGL6C20 372006
EI - Electrical connection	400 V, 3N, 50/60
G - Gas connection	1/2"



www.zanussiprofessional.com