

**Modular Cooking Range Line
EVO700 22 lt. Electric
Multifunctional Cooker with
compound bottom**

ITEM # _____

MODEL # _____

NAME # _____

SIS # _____

AIA # _____

**Modular Cooking Range Line****EVO700 22 lt. Electric Multifunctional
Cooker with compound bottom**

372110 (Z7MFEHDI00)

22-lt electric multifunctional
cooker with compound
cooking surface**Short Form Specification**

Item No. _____

Heating via incoloy armoured heating elements. To be installed on 50 mm high feet for cleaning ease. Well to have rounded corners and cooking surface in compound steel (a 3mm layer of 316 AISI stainless steel on top of a 12mm layer of mild steel). Exterior panels in stainless steel with Scotch Brite finish. One piece pressed work top in 1.5 mm thick stainless steel. Right-angled side edges to allow flush-fitting junction between units.

Main Features

- Multi purpose cooking appliance that can be used to shallow fry, cook liquids or even as a bain marie. Unit can be used for sautéing, poaching, steaming, simmering, stewing, braising, boiling and preparing white sauces.
- Well cooking surface made in compound steel (a 3mm layer of 316 AISI stainless steel on top of a 12mm layer of mild steel) for optimum grilling results.
- The stainless steel well to have rounded corners to facilitate cleaning.
- Bottom temperature control is precisely set by a thermostat on the control panel.
- Temperature can be set from 100 °C to 250 °C.
- Uniform temperature distribution over the whole base.
- Short heat-up time of the empty pan.
- Unit to be heated via incoloy armoured heating elements.
- Unit delivered with four 50 mm legs in stainless steel as standard (all round Stainless steel kick plates as option).

Construction

- All exterior panels in Stainless Steel with Scotch Brite finishing.
- One piece pressed 1.5 mm work top in Stainless steel.
- Model has right-angled side edges to allow flush fitting joints between units, eliminating gaps and possible dirt traps.

APPROVAL: _____

Included Accessories

- 1 of Scraper for smooth plate for fry tops PNC 164255
- 1 of Blades with rounded sides for scraper PNC 921694
for multifunctional cookers

Optional Accessories

- 4 wheels, 2 swivelling with brake (EVO700/900). It is mandatory to install with base supports for feet/wheels. PNC 206135
- Flanged feet kit PNC 206136
- Frontal kicking strip for concrete installation, 200 mm PNC 206146
- Frontal kicking strip for concrete installation, 400 mm PNC 206147
- Frontal kicking strip for concrete installation, 800 mm PNC 206148
- Frontal kicking strip for concrete installation, 1000 mm PNC 206150
- Frontal kicking strip for concrete installation, 1200 mm PNC 206151
- Frontal kicking strip for concrete installation, 1600 mm PNC 206152
- Frontal handrail 400 mm PNC 206166
- Frontal handrail 800 mm PNC 206167
- Frontal kicking strip, 200 mm PNC 206174
- Frontal kicking strip, 400 mm PNC 206175
- Frontal kicking strip, 800 mm PNC 206176
- Frontal kicking strip, 1000 mm PNC 206177
- Frontal kicking strip, 1200 mm PNC 206178
- Frontal kicking strip, 1600 mm PNC 206179
- Large handrail (portioning shelf) 400 mm PNC 206185
- Large handrail (portioning shelf) 800 mm PNC 206186
- Frontal handrail 1200 mm PNC 206191
- Frontal handrail 1600 mm PNC 206192
- 4 feet for concrete installation (not for 900 line freestanding grill) PNC 206210
- Right and left side handrails PNC 206240
- 2 supports with side runners for 4 GN 1/1 containers for open base cupboards (multifunctional cookers, solid top and gas ranges with cupboard) PNC 206244
- Central support for installation of drawers and grid supports for open base cupboards PNC 206245
- Pair of side kicking strips PNC 206249
- Pair of side kicking strips (concrete installation) PNC 206265
- Chimney upstand, 800 mm PNC 206304
- 2 side covering panels, height 700 mm, depth 700 mm PNC 206319
- Door for open base cupboard PNC 206342
- Base support for feet or wheels - 800mm (EVO700/900) PNC 206367
- Lid for 22lt multifunctional cooker PNC 921690

Front

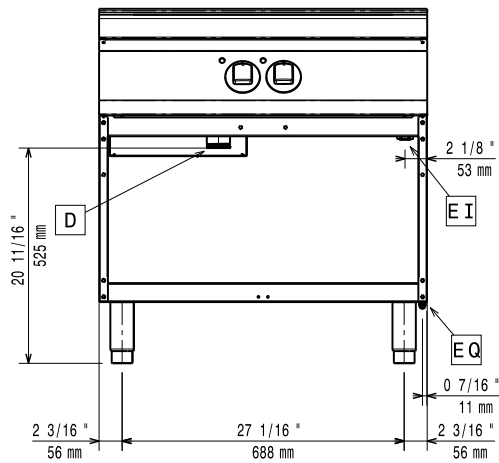

Top

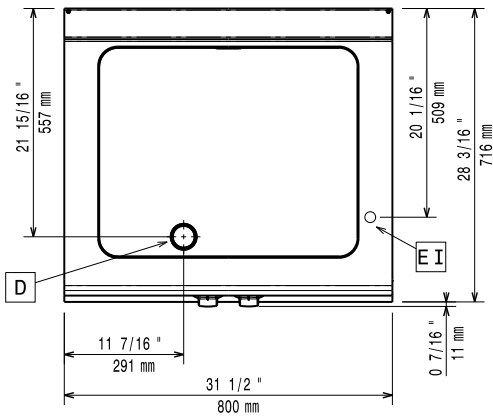

- EI = Electrical connection
- EQ = Equipotential screw
- F = Fumes outlet
- V = Air vents

Side

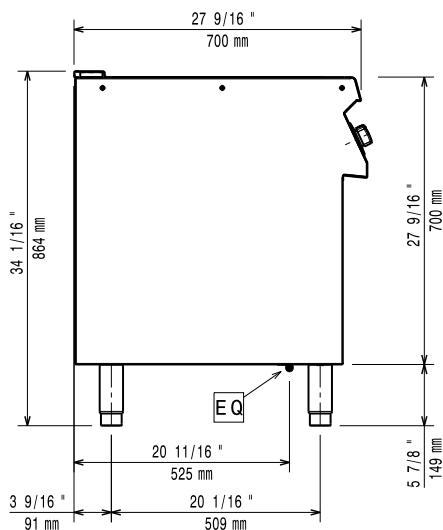

Electric

Supply voltage:

372110 (Z7MFEHDI00) 400 V/3N ph/50/60 Hz

Total Watts:

10 kW

Key Information:

Cooking surface width: 630 mm

Cooking surface depth: 510 mm

Cooking Well Height: 70 mm

Working Temperature MIN: 100 °C

Working Temperature MAX: 250 °C

Net weight: 75 kg

Shipping weight: 90 kg

Shipping height: 1140 mm

Shipping width: 820 mm

Shipping depth: 860 mm

Shipping volume: 0.8 m³

If appliance is set up or next to or against temperature sensitive furniture or similar, a safety gap of approximately 150 mm should be maintained or some form of heat insulation fitted.