

Modular Cooking Range Line EVO700 Freestanding Electric Pasta Cooker, 1 Well 24.5 litres

ITEM # _____

MODEL # _____

NAME # _____

SIS # _____

AIA # _____



Modular Cooking Range Line EVO700 Freestanding Electric Pasta Cooker, 1 Well 24.5 litres

372098 (Z7PCED1KF0) 24,5-lt electric pasta cooker
with 1 well

Short Form Specification

Item No. _____

Infrared heating system positioned below the well. Constant starch removal during the cooking process. Pressed tank in 316 AISI stainless steel to protect against corrosion. Manual water tap. Height adjustable feet in stainless steel. Exterior panels in stainless steel with Scotch Brite finish. One piece pressed work top in 1.5 mm thick stainless steel. Right-angled side edges to allow flush-fitting junction between units.

Main Features

- In addition to cooking pasta, the appliance can be used for noodles of every kind, rice, dumplings and vegetables.
- Unit to have infrared heating system positioned beneath the base of the well.
- Water basin in 316 type Stainless steel.
- Water basin is seamlessly welded into the top of the appliance.
- Provided with integrated drip zone on which baskets can be placed for draining purposes.
- 24.5 liters water basin.
- Unit to feature skimming zone for starch removal: improved water quality over time.
- Easy-to-use control panel.
- Safety thermostat to avoid operation without water.
- Continuous water filling regulated through a manual water tap.
- Large drain with manual ball-valve for fast emptying of well.
- **ESD** available as accessory (installed separately): energy saving device uses heat produced by water drained through the overflow to pre-heat tap-in water up to 60°C, for constant water boiling.
- **EnergyControl**: unique feature for fine power adjustment to control boiling level and optimize energy consumption.
- **Automatic lifting system** (optional accessory): 200mm wide unit with two stainless steel basket supports, holding one GN 1/2 basket each, to be placed on either or both sides of machine to provide automatic lifting for four small portion baskets (to be ordered separately). Possibility to memorize nine cooking times through digital control.
- All major compartments located in front of unit for ease of maintenance.
- IPX4 water resistance certification.
- Unit delivered with four 50 mm legs in stainless steel as standard (all round Stainless steel kick plates as option).

Construction

- All exterior panels in Stainless Steel with Scotch Brite finishing.
- One piece pressed 1.5 mm work top in Stainless steel.
- Model has right-angled side edges to allow flush fitting joints between units, eliminating gaps and possible dirt traps.

APPROVAL: _____

Included Accessories

- 1 of Door for open base cupboard PNC 206342

Optional Accessories

- 4 wheels, 2 swivelling with brake (EVO700/900). It is mandatory to install with base supports for feet/wheels. PNC 206135
- Flanged feet kit PNC 206136
- Frontal kicking strip for concrete installation, 200 mm PNC 206146
- Frontal kicking strip for concrete installation, 400 mm PNC 206147
- Frontal kicking strip for concrete installation, 800 mm PNC 206148
- Frontal kicking strip for concrete installation, 1000 mm PNC 206150
- Frontal kicking strip for concrete installation, 1200 mm PNC 206151
- Frontal kicking strip for concrete installation, 1600 mm PNC 206152
- Frontal handrail 400 mm PNC 206166
- Frontal handrail 800 mm PNC 206167
- Frontal kicking strip, 200 mm PNC 206174
- Frontal kicking strip, 400 mm PNC 206175
- Frontal kicking strip, 800 mm PNC 206176
- Frontal kicking strip, 1000 mm PNC 206177
- Frontal kicking strip, 1200 mm PNC 206178
- Frontal kicking strip, 1600 mm PNC 206179
- Large handrail (portioning shelf) 400 mm PNC 206185
- Large handrail (portioning shelf) 800 mm PNC 206186
- Frontal handrail 1200 mm PNC 206191
- Frontal handrail 1600 mm PNC 206192
- 4 feet for concrete installation (not for 900 line freestanding grill) PNC 206210
- Right and left side handrails PNC 206240
- Pair of side kicking strips PNC 206249
- Pair of side kicking strips (concrete installation) PNC 206265
- Water column with swivel arm (water column extension not included) PNC 206289
- Water column extension PNC 206291
- Chimney upstand, 400 mm PNC 206303
- 2 side covering panels, height 700 mm, depth 700 mm PNC 206319
- Door for open base cupboard PNC 206342
- Energy saving device for pasta cookers PNC 206344
- Automatic programmable basket lifting system for 24.5lt pasta cookers, 2 lifters PNC 206354
- Base support for feet or wheels - 400mm (EVO700/900) PNC 206366
- Base support for feet or wheels - 800mm (EVO700/900) PNC 206367
- Chimney grid net, 400mm PNC 206400
- Support frame for 4 baskets for 24,5lt pasta cookers PNC 921606
- Lid for 24,5lt pasta cookers PNC 921607
- 2 half size baskets 170x220 for 24,5lt pasta cookers PNC 921610
- Full size basket for 24,5lt pasta cookers PNC 921611
- 2 half size baskets 105x350 for pasta cookers for 24,5lt pasta cookers PNC 921619

Modular Cooking Range Line EVO700 Freestanding Electric Pasta Cooker, 1 Well 24.5 litres

Front

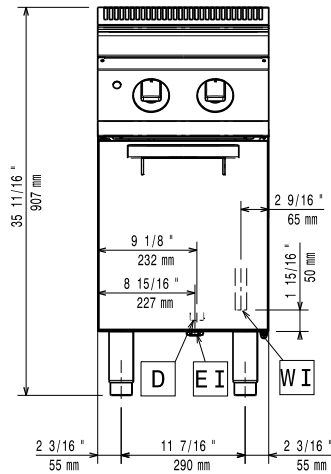

Top

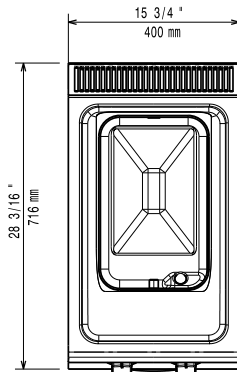

D = Drain
EI = Electrical connection
EQ = Equipotential screw

Side

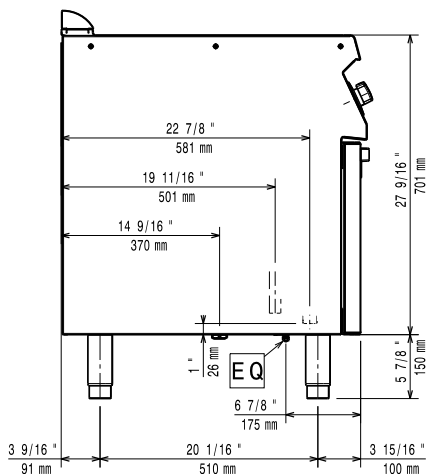

Electric

Supply voltage:

372098 (Z7PCED1KF0) 400 V/3N ph/50/60 Hz

Electrical power:

6 kW

Total Watts:

6 kW

Water:

Drain "D":

1"

Incoming Cold/hot Water line size:

1/2"

Total hardness:

5-50 ppm

Electrolux recommends the use of treated water, based on testing of specific water conditions.

Please refer to user manual for detailed water quality information.

Key Information:

Usable well dimensions (width):	250 mm
Usable well dimensions (height):	300 mm
Usable well dimensions (depth):	400 mm
Well Capacity (MAX):	24.5 lt MAX
Net weight:	50 kg
Shipping weight:	50 kg
Shipping height:	1140 mm
Shipping width:	460 mm
Shipping depth:	820 mm
Shipping volume:	0.43 m ³

If appliance is set up or next to or against temperature sensitive furniture or similar, a safety gap of approximately 150 mm should be maintained or some form of heat insulation fitted.