



MODULAR COOKING EV0700

ZANUSSI
PROFESSIONAL



MODULARITY ACCORDING TO ZANUSSI

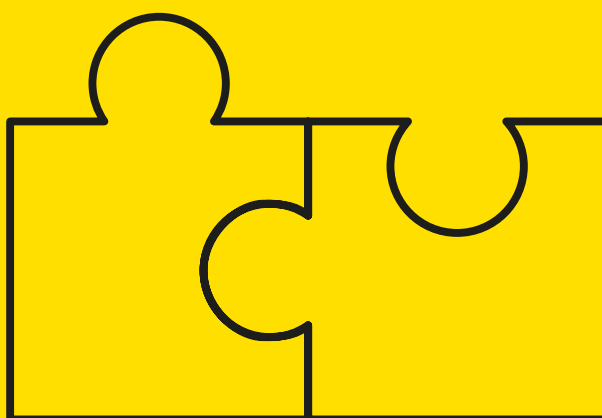

Zanussi Professional has been designed with performance, reliability and sturdiness in mind. Thanks to its exceptional modularity, all you need to think about is the configuration that best suits your method of cooking.

Evo700 brings together tradition and innovation. Evo700 gives you excellent performance together with energy saving. No matter what kind of cooking you have chosen, the result will always be perfect.

ENDLESS MODULARITY



GAS COOKERS
2, 4, or 6 burners
top or free standing



ELECTRIC COOKERS
2, 4 or 6 round plates
4 square plates
top or free standing



INDUCTION HOBS
2 or 4 zones
2 frontal zones



INFRA-RED HOBS
2 or 4 zones
top or free standing



SOLD TOPS
gas
top or free standing



FRY TOPS
gas or electric
versions



GRILLS

gas or electric versions



HP GRILLS

gas or electric top versions



FRYERS

gas or electric versions



BOILING PANS

gas or electric versions



BRAISING PANS

gas or electric versions



PASTA COOKERS
gas or electric versions



MULTIFUNCTIONAL COOKERS
gas or electric versions



BAIN-MARIES
electric versions



WORKTOPS



REFRIGERATED BASES



NEUTRAL UNITS

SOLID, COMPACT AND ERGONOMIC COOKING

PASTA COOKER

Versatile and high performing, thanks to the “**energy control**” for gas models, the infrared heating system for the electric models and the “**energy saving device**” for the refilling of the well with hot water.

HP INDUCTION

For those who love speed and want to save energy. The glass ceramic surface activates the induction ring only when it comes into contact with the pot.



PLUS

Range

Complete, reliable, solid and safe.

Choice

Induction, infra-red, gas and electric solutions.

Saving

Innovative devices for energy saving.

Sustainability

98% recycling of the equipment and 100% packaging.

EFFICIENT SAVING

The **exclusive “flower flame”** system for gas burners allows the flame to be precisely adjusted to fit pans of any diameters, thus avoiding dispersion into work area and providing high efficiency.

to
ace
n it

CHROME FRY TOP

for cooking of different kinds of food, meat, fish and vegetables with **maximum efficiency** and no flavour transfer.



MULTI-PURPOSE COOKER

Easy to use, empty and clean. Highly suited for cooking in different modes: grilling, braising, holding and boiling.

GREAT POWER, EASY CONTROL



-
- The high quality steel ensures duration and quality
 - The corners are all smooth and rounded to make cleaning easier
 - The modularity is guaranteed by perfect adherence between modules

The burners are fitted with Flower Flame, a technology that permits to regulate the flame, adjusting it to the surfaces of the pan base.

GAS COOKING, EFFICIENT POWER

FLOWER FLAME ENSURE GREATER SAVINGS

All the specifications converge to make Evo700 more **solid and powerful**. The back and side panels are made up of a single element to ensure duration and stability; the work surface is 1.5 mm thick stainless steel and is moulded in a single piece, without welding and smooth, rounded corners. The side edges are laser cut at right angles so they fit perfectly with the other units. The pot supports are in cast iron. All the burners are fitted with an anti-extinguishing device and

highly efficient Flower Flame.

The pilot flame is protected. The exclusive Flower Flame burners allow for the expansion of the flame both horizontally and vertically in order to adapt to the varying diameters of the pot base. The perfect temperature is reached faster and heat dispersion is at a minimum.



GAS STATIC OVEN

→ Its power is 6 kW and the operating temperature varies between 110 °C and 270 °C.

More speed and greater performance.

- The cooking chamber is entirely made of stainless steel.
- Insulation is guaranteed by the 40 mm thick door.
- The oven is fitted with removable stainless steel runners.

- For greater ergonomics the oven knobs are positioned on the upper control panel.
- The piezoelectric ignition is faster.
- The cooking chamber is on 3 levels for GN 2/1 trays.



THE GAS POWER

SAFETY IS SOLID AND RELIABLE



-
- The cast iron griddles have a safety thermostat
 - Cleaning is made easier by the moulded steel surface
 - Sturdiness and solidity are guaranteed by the single piece panels

If your choice falls with electric cooking, you will find the same reliability, safety and duration that have made Zanussi Professional the partner par excellence of good traditional cooking.

ELECTRIC COOKING SAFETY AND EFFICIENCY

GUARANTEED SOLIDITY

Safe, reliable and very easy to clean. The cast iron griddles are either round or square, fitted with safety thermostat and are hermetically sealed onto the work surface. Individually controlled hot round or square plates, (2,6 kW each), with step regulation. The surface is in a single piece and is moulded in 1.5 mm stainless steel.

All the corners are rounded to make cleaning even easier and faster. Even

the side and back panels are made of single element to ensure greater durability and stability. All the external panels have a Scotch-Brite finish. The side edges are laser cut at right angles so they fit perfectly with the other units.



ELECTRIC STATIC OVEN

- The door has a double wall and is insulated. The internal panel is moulded for a perfect air-tight closure and increased hygiene.
- The oven cavity is made of stainless steel with an enameled steel base.
- The internal chamber has 3 levels for resting GN 2/1 trays.
- The upper and lower heating elements can work separately or simultaneously.
- The thermostat can be regulated from 140 °C to 300 °C.



ALL ONE PIECE

INNOVATION MAKES COOKING EASIER



-
- Technological innovation offers a new kind of cooking
 - Induction guarantees power, speed and delicacy all in one
 - All the surface cleaning operations are easy and fast

With high technology cooking surfaces, all types of cooking becomes faster, while heat dispersion is almost completely eliminated.

EVEN THE INDUCTION WOK FOR THOSE WHO LOVE FUSION COOKING

FASTER AND WITH NO HEAT DISPERSION.

The 6 mm glass ceramic surface ensures safety, maximum cleaning and easy movement of the pans. The power has a greater, more precise regulation.

The induction is **perfect for delicate cooking as well as sauté cooking**. The work surface is made of 1.5mm stainless steel, moulded in a single piece with smooth, rounded corners. All the external panels are made of stainless steel with Scotch-Brite finish.

Both the side and back panels are made of a single piece to provide resistance and stability.

The side edges are laser cut at right angles to make it easier to fit perfectly with the other units. The cooking surfaces, made of 6 mm thick Ceran ceramic glass®, are robust and reliable.

The induction rings have separate power control (230 mm diameter - from 3.5 kW and 5 kW HP version) which can be set to 9 different levels. An indicator light shows whether the surface is operational.

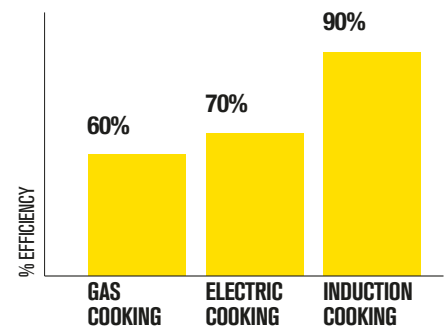

Energy effectively transmitted to the content of the cooking container compared to the amount of heating produced by the system (internal laboratory tests).

AVAILABLE VERSIONS

Induction wok

- Robust and reliable wok in 6 mm thick Ceran ceramic glass®.
- Single ring with a safety device to prevent overheating.
- Control panel with 9 power levels and indicator light that shows when the surface is operational.

Front induction surface with spice rack

- 2 rings with independent power control (5 kW HP and a diameter of 230 mm), each with a safety device to prevent overheating.
- 6 GN 1/9 containers with lid.



SPEED AND POWER

ALL THE POWER YOU DESIRE

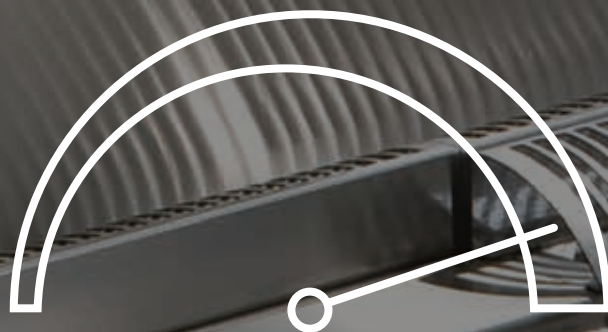

-
- With infra-red cooking the selection is complete
 - The obstacle free surface guarantees easy movement of the pots
 - All the cleaning operations are faster

Thanks to its high technology cooking surfaces, heat dispersion into the environment is almost completely eliminated.

EVERY INFRA-RED AREA HAS INDEPENDENT CONTROL

INFRA-RED HOBS

The infra-red cooking surfaces allow for **faster cooking even when starting from cold.**

The heating elements have 2 concentric circular rings with a maximum diameter of 230 mm and are controlled by an energy regulator. The 6 mm glass ceramic surface ensures maximum cleaning and easy movement of the saucepans.

A warning light indicates the presence of any residual heat.

The work surface is in a moulded, 1.5 mm thick stainless steel single piece with smooth, rounded corners. All the external panels are made of stainless steel with Scotch-Brite finish.

The side and back panels are made up of a single element to provide greater resistance and stability.

Infra-red rings have separate power control (230 mm diameter – 2.2 kW)
The heating elements are concentric and are activated depending on the surfaces of the bottom of the pot.



STARTING FROM COLD

SOLID TOPS PLATES FOR AMPLE COOKING SURFACE

GAS, WORK ON THE WHOLE SURFACE

The solid top is fitted with a vast cast iron griddle with a useful surface for resting pots up to 800x700 mm. The work surface is in a moulded, 1.5 mm thick stainless steel single piece with smooth, rounded corners. All the external panels are made of stainless steel with Scotch-Brite finish and come in a single piece to provide **greater resistance and stability**.

The side edges that are laser cut at right angles, allow them to fit perfectly with the other units.

The cooking surface is made of 30 mm cast iron for **long-term durability** and is, at differentiated temperatures, a maximum of 500 °C at its centre to a minimum of 200 °C on its edges. The burner is single and central with an optimised combustion system and anti-extinguishing device. The ignition is piezoelectric and the pilot flame is protected.



ELECTRIC, COOKING ACROSS THE BOARD

The electric solid top is equipped with a vast steel griddle with a useful surface for resting pots.

The work surface is made of 1.5 mm thick stainless steel, moulded in a single piece with smooth, rounded corners.

The external panels are made of stainless steel with Scotch-Brite finish and are cut in a single piece to provide greater resistance and stability.

All the side edges are laser cut at right angles so they fit perfectly with the other units.

The cooking surface is made of 16M03 steel and is 15 mm thick to **ensure resistance and durability**.

You can have 2 or 4 separate cooking rings for maximum working flexibility. Every cooking ring is controlled by 2 sensors to optimise performance and monitor consumption.

The maximum achievable temperature is 440 °C. The heating elements are infra-red.



LARGE SURFACES

STEEL OR CHROME FRY TOPS FOR CONSTANTLY PERFECT COOKING

HEAT UNIFORMITY

The Evo700 fry tops are designed to ensure that the **desired temperature is reached quickly**, the **heat distribution is uniform** and there is **minimum heat dispersion**.

The cooking surface is a moulded, 1.5mm thick single piece and its corners are rounded to provide easier, more accurate cleaning. You can choose a griddle that is smooth, ribbed or a mixture of both, with versions made of mild steel or chrome.

The external panels are made of stainless steel with Scotch-Brite finish.

The side and back panels are made up of a single element to provide

greater resistance and stability.

The side edges that are laser cut at right angles allow them to fit perfectly with the other units.

The 12 mm thick cooking griddle guarantees uniform temperature distribution.

Extended useful surface with frontal holding zone.

Possibility of choosing between a mild steel or chrome cooking surface.

There is a wide drainage hole and a grease collection tray is provided.

The 5 litre grease collection drawer for open base installation is optional.

The stainless steel backsplash is situated on three sides and can be removed to make cleaning easier.



AVAILABLE VERSIONS

Gas versions

- In the mild steel surface version, the temperatures vary between 200 °C and 400 °C.
- In the chrome version, there is a thermostatic temperature control and safety thermostat. Temperatures vary between 130 °C and 300 °C.
- The ignition is piezoelectric.

Electric versions

- Infra-red heating elements located under the cooking surface.
- Thermostatic control and safety thermostat on all the models.
- Temperatures vary between 120 °C and 280 °C in the mild steel version and between 110 °C and 300 °C in the chrome versions.



SMOOTH OR RIBBED

GRILLS, THE TRADITIONAL CHOICE FOR MEAT, FISH AND VEGETABLES

FOR THOSE WHO LOVE TRADITIONAL COOKING

The grills are the perfect solution for cooking meat, fish and vegetables. The external panels are made of stainless steel with Scotch-Brite finish. There is stability and resistance thanks to the side and back panels that are made up of a single element. The side edges that are laser cut at right angles allow them to fit perfectly with the various other units. The grease collection tray can be filled with water to make cleaning easier and maintain the humidity of the food. The stainless steel backsplash is

situated on three sides and can be removed to make cleaning easier. In the single unit models the cast iron grills are used on two sides: ribbed for cooking meat and smooth for grilling fish or vegetables. A useful scraper is provided to clean the grill.



AVAILABLE VERSIONS

Gas grills

- The burners are made of stainless steel with an anti-extinguishing device and protection plates that prevent clogging.
- Lavastone gas grill version

Electric grills

- The armoured heating elements made of incoloy are under the cooking griddle.
- The heating elements can be lifted up frontally to make cleaning easier.
- A light indicates when the grill is on.



MAKE YOUR CHOICE

GAS HP GRILL

Gas HP grill combines **high productivity and energy savings**.

It has a vast cooking surface and the robust cast iron grills.

The Energy Control allows for an exact regulation of the power level.

The radiation heating system is highly efficient.

→ The stainless steel burners have an optimised combustion system, an anti-extinguishing device, protected pilot flame and piezoelectric ignition.

Radiation heating system

→ An efficient combustion of the burner flame guaranteed by the incoming air.

→ The burner flame heats the AISI 441 radiant shield, bringing the temperature above 700°C

→ The maximum temperature of the cooking surface is 300 °C.

→ The total depth grease collection tray, one for each burner, can be filled with water to make cleaning easier and maintain the humidity of the food.

→ Polished finishing of cast iron grids makes cleaning easier.

→ The stainless steel backsplash on three sides can be removed to make cleaning easier.

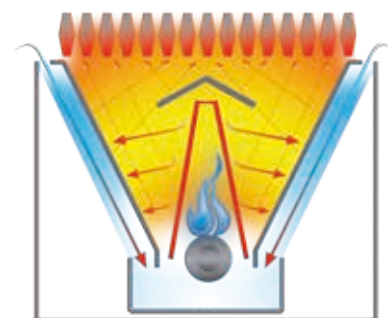

Radiation heating system

ELECTRIC HP GRILL

Now you have one more choice.

The new High Performance Electric HP Grill. **Perfect performance and cooking results even under stress.**

→ Cooking times are much faster and power regulation is more precise. The power can be kept to a minimum, and reaches necessary setting in record time.

→ The heat distribution is uniform, thanks to the new heating element in contact with innovative removable U-shaped grid.

→ The cooking is therefore homogeneous throughout the surface.

→ 120cm wide version is available to cook more variety of food without mingling of flavors.

→ Cleaning is the easiest thing. Heating elements can be tilted up to 90°. Cooking grids are fully removable and washable in the dishwasher.

→ The integrated water tap and drain speed up all the operations.

→ Each 40cm bank of heating elements is regulated independently allowing partial use of the grill or simultaneous cooking of different products.

→ From heating-up to the final cleaning, the workflow is precise and meticulous. Without gaps and quick. The grill can also be installed on refrigerated base.



HIGH PRODUCTIVITY

FRYERS. GREATER POWER THANKS TO THE SPECIAL WELL DESIGN

HIGH OUTPUT FOR EACH VERSION

The 1.5mm thick stainless steel work surface is moulded in a single piece and has smooth, rounded corners to make cleaning easier. The external panels are made of stainless steel with Scotch-Brite finish. The stability comes mainly from the side and back panels which are made of a single piece of steel.

The side edges are laser cut at right angles so that they fit together with more precision with the other units. Oil drainage valve. Temperature thermostatic control with safety thermostat against overheating.



AVAILABLE VERSIONS

V-shaped well gas fryers

- The well is V-shaped with high output external stainless steel burners and with optimised combustion system.
- Furthermore, they come equipped with an anti-extinguishing device, protected pilot flame and piezoelectric ignition.
- Thermostatic temperature control varies between 105 °C and 185 °C.
- Perfect for bread-crumbed and floured food and for use in pastry making.

Fryers with gas flame pipes.

- 34 litre capacity fryer with burners positioned inside the tubes immersed into the oil for fast heat-up.

- Stainless steel burners with optimised combustion system, anti-extinguishing device and protected pilot flame.
- Thermostatic temperature control varies between 110 °C and 190 °C.
- Safety thermostat against overheating.
- Piezoelectric ignition.

Electric fryers

- 7 and 15 litre V-shaped well with high efficiency external infra-red heating elements.
- 2x5, 12, 14 litre well with incoloy heating elements.
- Thermostatic temperature control varying between 105°C and 185°C.



V-SHAPED WELL

AUTOMATIC FRYER

The 15 litre V-shaped well with external electric heating elements offers **power, efficiency** and the capacity to bring the oil quickly to the perfect frying temperature. The temperature and cooking time are checked electronically. The actual temperature and the cooking program are always visible.

The automatic basket lifting system is supplied with 5 different programs (5 temperatures and 2 lifting times per program). The "Melt" function is used for solid frying fats.



ELECTRIC CHIP SCUTTLE

The chip scuttle with AISI316 well is essential for salting and maintaining the temperature of the fried food after cooking.

- The work surface is made of a moulded, 1.5 mm thick stainless steel piece with smooth, rounded corners for faster cleaning.
- The stainless steel external panels have a Scotch-Brite finish.
- The side and back panels are made of a single piece to provide greater resistance and stability.
- The side edges are laser cut at right angles so they fit perfectly with the other units.

- There is a false bottom with holes to drain any excess oil into the collection well.
- Infra-red heating lamp located in the upper and back part of the unit.



AUTOMATIC EFFICIENCY

PASTA COOKERS CONSUMPTION CONTROLLED WITH GUARANTEED SAVINGS

NOT ONLY FOR PASTA

The Pasta Cookers in the Evo700 line guarantee high productivity and remarkable thermal performance. Versatile and high performing thanks to the **“energy control”** for the gas models, the **infrared heating system** for the electric models and the optional **“energy saving device”** for the refilling of the well with hot water. The **“energy saving device”**, optional for all models, allows the refilling of the well, done with hot water so boiling is constant, providing the best cooking results, increasing **productivity** and **saving energy**.

- 1-piece pressed work top in stainless steel (1,5 mm) with smooth rounded corners
- Exterior panels in stainless steel with Scotch-Brite finishing

- T1-piece side and rear panels for durability and maximum stability.
- Right-angled, laser cut side edges for flush fitting.
- Boiling wells in 316L AISI stainless steel with seamless welding.
- Electromechanical sensor prevents operation without water.
- Self-skimming system with continuous water filling regulated through manual water tap.
- Large drain with manual ball-valve for fast emptying of the well.
- Automatic basket lifting system (optional).



AVAILABLE VERSIONS

Gas models

- The Energy Control system regulates the level of power with precision and adjusts consumption to the actual requirements.
- The high efficiency burners (one for each well) are located under the bottom of the tub and are fitted with an anti-extinguishing device, pilot flame and piezoelectric ignition.
- No further energy supplied is needed.

Electric models

- Infra-red heating system located under the bottom of the well.
- 4 different cooking cycles, from simmering to boiling.



CONSTANT BOILING POINT

AUTOMATIC BASKET LIFTING SYSTEM

Programmable and automatic lifting system guarantees the repeatability of the cooking cycle, ensuring the same high quality of the food time after time due to the automation of the entire cooking process.

- Possibility to **memorize 9 cooking times** via digital control. Each lifter can work **independently** from the others.
- Easy operation, basket lifting is activated through a simple push button function.
- Can be activated manually if necessary.

- 200 mm wide, with 2 stainless steel basket supports, each able to hold 1/2 size baskets.
- Place on either side of the pasta cooker for maximum flexibility or on both sides to provide lifting for up to 4 single portion square baskets.



REPEATABLE CYCLES

BOILING PANS MANY VERSIONS AND A CONSIDERABLE POWER

COOKING UNIFORMITY

Thanks to the Energy Regulator, the Evo700 boiling pans guarantee **uniform cooking** and a **precise boiling control**. The innovative stainless steel gas burners, controlled by an electronic ignition pilot flame, guarantee an optimised combustion and high efficiency.

- A stainless steel, moulded well and double wall lid.
- The external, stainless steel panels have a Scotch-Brite finish.
- A deep well with rounded corners and welding without joints that makes it easier to clean.
- A safety valve that ensures the operating pressure is kept steady in the indirect heating models.

- Solenoid valve to provide hot and cold water.
- Valve for manual discharge of excess air, accumulated in the dry area during the heating phase (indirect heating versions).
- Front tap for food disposal.



AVAILABLE VERSIONS

Gas models

- Stainless steel burners with optimised combustion system, anti-extinguishing device, temperature limiter and protected pilot flame.

Electric models

- Heating elements with energy control, temperature limiter and manostat.

Direct heating in gas models

- The well is heated directly from the burners, so the food can reach a higher temperature than the indirect heating models.

Indirect heating for gas or electric models

- Generation of overflowing steam at 110 °C in the double jacket.
- Pressure switch control.
- Models with automatic water re-filling system in the air cavity, are available.



EFFICIENCY AND CAPACITY

BRAISING PANS TWO STEELS OF YOUR CHOICE

PRECISION EMPTYING

All Evo700 Braising Pan models have stainless steel wells that are shaped with rounded corners and with a pressed drainage pouring lip to make both food drainage and cleaning operations easier.

- Well with rounded corners and **seamless welding**.
- Double skinned lid in stainless steel.
- Exterior panels in stainless steel with Scotch-Brite finishing.

- 1-piece side and rear panels for durability and maximum stability.
- Cooking surface in mild steel especially indicated for “dry cooking” or “shallow frying”.
- Cooking surface in “**Duomat**” especially indicated for “**wet cooking**”.
- High precision manual tilting system.



AVAILABLE VERSIONS

Gas models

- Burners with optimized combustion, flame failure device and piezo ignition with electronic flame control.
- Thermostatic temperature control from 90°C to 290°C.

Electric models

- Infrared heating elements positioned beneath the cooking surface.
- Heating elements built-in to the base of the well move together during tilting.
- Thermostatic temperature control from 120°C to 300°C.



LARGE SCALE COOKING

MULTI-FUNCTIONAL COOKERS FOR FLEXIBILITY WITHOUT COMPARISON

4 IN 1

- 4 appliances in one!** Can be used as a fry top, braising pan, boiling pan or bain-marie, a must for a kitchen needing maximum flexibility.
- 1-piece pressed work top in stainless steel (1,5 mm) with smooth rounded corners.
 - Exterior panels in stainless steel with Scotch-Brite finishing.
 - **1-piece side and rear panels** for durability and maximum stability.
 - Right-angled, laser cut side edges for flush fitting of units.
 - Stainless steel well with rounded

- corners, seamlessly welded to the work top.
- Cooking surface in **compound steel** (3 mm layer of 316 AISI stainless steel bonded to a 12 mm layer of mild steel), optimal for multifunctional use.
- **Base contains guides** which can host GN containers to collect the food drained through the large drain hole.



AVAILABLE VERSIONS

Gas models

- Burners equipped with a double flame line for uniform heat distribution.
- Thermostatic gas valve. Piezo ignition.
- Temperature range from 100°C to 250°C.
- Temperature varies between 100 °C and 250 °C.

Electric models

- Incoloy armoured heating elements beneath the cooking surface.
- Thermostatic control and energy regulator for precise cooking control and a reduction in the fluctuation of energy around the set temperature.
- Temperature range from 100°C to 250°C.



FOUR IN ONE

BAIN-MARIE NEUTRAL TOPS SINK TOP

BAIN-MARIE

The work surface is made of 1.5 mm thick, stainless steel moulded in a single piece with smooth, rounded corners.

The external panels are made of stainless steel with a Scotch-Brite finish.

The side and back panels are a single piece to provide greater resistance and stability.

The side edges are laser cut at right angles so they ensure a perfect fit

with the other units.

The stainless steel well has rounded corners and joint-free welding.

→ Suitable for GN 1/1 containers with a max. height of 150 mm.

→ Temperature varies between 30°C and 90°C.

→ Maximum level of water indicated on the side of the well.

→ Manual water re-filling

→ The tap can be requested as an optional accessory.



NEUTRAL TOPS

→ The work surface is made of 1.5 mm thick stainless steel, moulded in a single piece with smooth, rounded corners.

→ The stainless steel external panels have a Scotch-Brite finish.

→ The side and back panels are made

of a single piece to provide greater resistance and stability.

→ Option to select front closure or with drawer.



SINK TOP

→ The stainless steel external panels have a Scotch-Brite finish.

→ The side and back panels are made of a single piece to provide greater resistance and stability.

→ Compatible with GN 1/1 well.



A VAST CHOICE

WATER COLUMN, NEUTRAL AND COOLING BASES

WATER COLUMN

- The stainless steel external panels have a Scotch-Brite finish.
- The side and back panels are made of a single piece to provide greater resistance and stability.
- Digital litre counter to monitor the water load.



NEUTRAL BASES AND REFRIGERATED BASES

Open neutral bases

- The external, stainless steel panels have a Scotch-Brite finish.
- Optional accessories:
 - doors with handles
 - drawers
 - runners for GN containers
 - heating kit.

Refrigerated and freezer base

- Temperature from $-2\text{ }^{\circ}\text{C}$ to $+10\text{ }^{\circ}\text{C}$ for the refrigerated base and temperature from $-15\text{ }^{\circ}\text{C}$ to $-20\text{ }^{\circ}\text{C}$ for freezer base.
- Cooling unit incorporated.
- Thermostat, defrosting light and on/off switch.
- Large stainless steel drawers with telescopic runners suitable for GN 1/1 containers.
- Suitable for an external temperature of up to $43\text{ }^{\circ}\text{C}$.
- Automatic evaporation of defrost condense.



COMPLETE RANGE

COMPLETE SOLUTIONS FOR EVERY NEED

INSTALLATION ON FEET

- Standard solution, ideal when needing a fixed installation of appliances that can be adjusted in height.
- Provided as standard on all free standing appliances and bases.

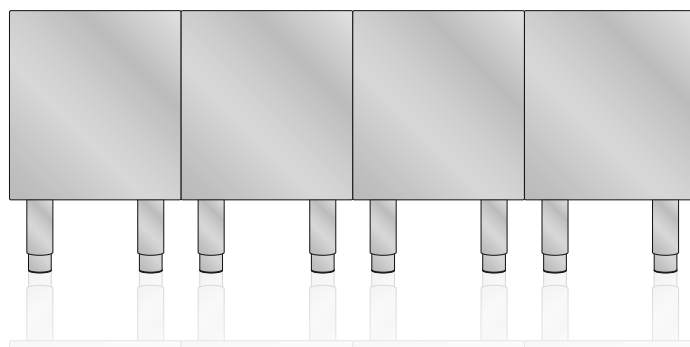

INSTALLATION ON A CEMENT PLINTH

- Provides a closed solution to be mounted on cement plinth - various solutions available*.
- Suitable for all free standing units*.

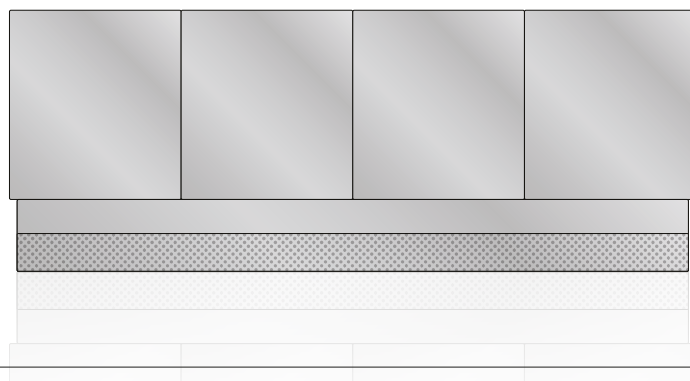

CANTILEVER INSTALLATION

- Provides an aesthetic and hygienic solution by use of a supporting frame. Can be used for one side and back-to-back installations.
- Suitable for most units* of Evo700 and Evo900.

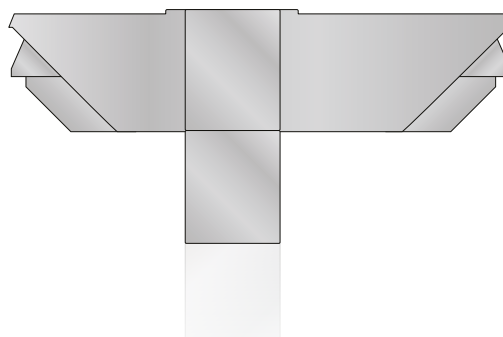

* For further information, contact the Zanussi Professional Sales manager

FLEXIBILITY

BRIDGE INSTALLATION

- Provides a hygienic solution by allowing to suspend a number of top appliances between two free standing units.
- Must be installed between two free standing units up to 1600 mm in length*.
- Free standing units - can be installed up to 2000 mm in length*

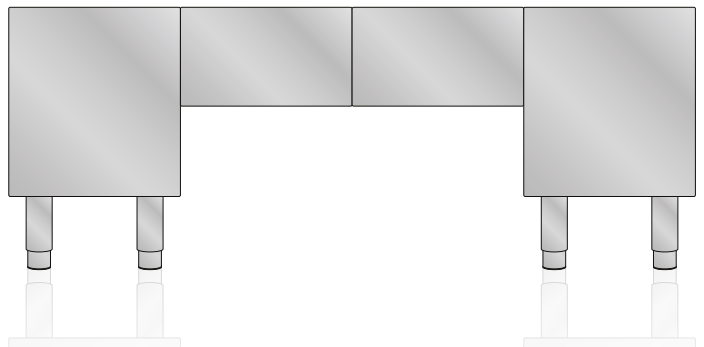

INSTALLATION WITH KICKING STRIP

- Covers the feet to close the area between the appliances and the floor.
- Can be applied to free standing appliances and bases installed on feet.

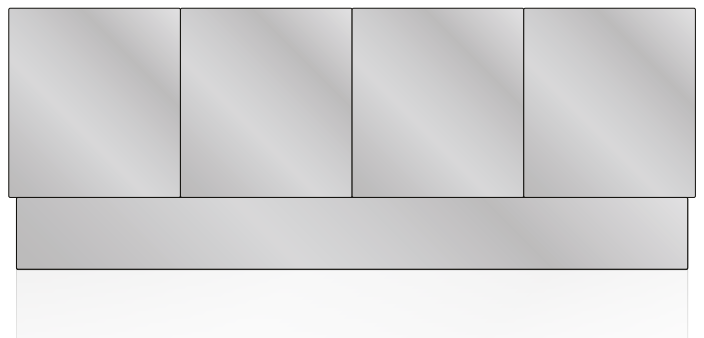

INSTALLATION ON WHEELS

- Replace feet, provides a flexible solution that allows for the easy movement of the appliances.
- Can be installed on all free standing appliances and bases*.

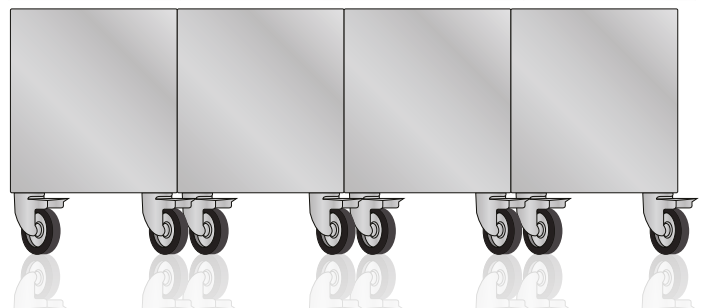

* For further information, contact the Zanussi Professional Sales manager

MODULARITY

WHEN YOU NEED IT ZANUSSI IS THERE FOR YOU



Before and after sales, trust an expert

Listening and collaboration: these are two key words for us. Our engineers collaborate with chefs and technicians to define exactly what the features will be of an ever more reliable and easy-to-use product.

Our collaborators are consultants first and foremost

Our consultants can recommend the best machine, with the most services and which best adjusts to the client's work project specifications. The after-sales service has an extensive presence and is fast and efficient.

Our courses help you discover the full potential of our machines

Our courses are conducted by professionals for professionals for two reasons: to provide chefs and operators in the kitchen with updates on cooking techniques and more detailed information on our machines so they can produce more and consume less.



The company reserves the right to change technical specifications without prior warning. The photographs are not contractually binding.

ZANUSSI PROFESSIONAL
www.zanussiprofessional.com

ZANUSSI
PROFESSIONAL