

Modular Cooking Range Line EVO900 Two Wells Electric Fryer 23 liter

ITEM # _____

MODEL # _____

NAME # _____

SIS # _____

AIA # _____



Modular Cooking Range Line

EVO900 Two Wells Electric Fryer 23 liter

392090 (Z9FREH2JF0)

23+23-lt electric fryer with 2 "V" shaped wells (external heating elements) and 4 half size baskets - free standing

Short Form Specification

Item No. _____

High efficiency infrared heating elements (36kW) attached to the outside of the wells. Deep drawn V-Shaped wells. Oil drains through a tap into a container positioned under the wells. Height adjustable feet in stainless steel. Exterior panels in stainless steel. Worktop in 20/10, stainless steel. Right-angled side edges eliminate gaps and possible dirt traps between units.

Main Features

- Deep drawn V-Shaped wells.
- Interior of wells with seamlessly laser-welded corners for ease of cleaning.
- External infrared heating elements for ease of cleaning of internal well.
- Thermostatic regulation of oil temperature up to a maximum of 185 °C.
- Overheat protection thermostat as standard on all units.
- Oil drains through a tap into a drainage container positioned under the well.
- All major compartments located in front of unit for ease of maintenance.
- IPX5 water resistance certification.
- The special design of the control knob system guarantees against water infiltration.
- Unit delivered with four 50 mm legs in stainless steel as standard (all round Stainless steel kick plates as option).
- Supplied as standard with 4 half size baskets and 1 right and left side doors for cupboard.

Construction

- All exterior panels in Stainless Steel with Scotch Brite finishing.
- Model has right-angled side edges to allow flush fitting joints between units, eliminating gaps and possible dirt traps.
- Unit is 900mm deep to give a larger working surface area.

APPROVAL: _____

Included Accessories

- 2 of Door for open base cupboard PNC 206342
- 2 of 2 half size baskets for 18/23lt well fryers PNC 927223

Optional Accessories

- Junction sealing kit PNC 206086
- 4 wheels, 2 swivelling with brake (EVO700/900). It is mandatory to install with base supports for feet/wheels. PNC 206135
- Flanged feet kit PNC 206136
- Side handrail for right/left hand PNC 206165
- Frontal handrail 400 mm PNC 206166
- Frontal handrail 800 mm PNC 206167
- Sediment tray for 23lt fryer PNC 206173
- Pair of side kicking strips PNC 206180
- Large handrail (portioning shelf) 400 mm PNC 206185
- Large handrail (portioning shelf) 800 mm PNC 206186
- Frontal handrail 1200 mm PNC 206191
- Frontal handrail 1600 mm PNC 206192
- Hygienic lid for 23lt fryers PNC 206201
- Frontal kicking strip for 23lt fryers in two parts PNC 206203
- Extension pipe for oil drainage for 15lt, 18lt, 23lt fryers PNC 206209
- Chimney upstand, 800 mm PNC 206304
- 2 side covering panels, height 700 mm, depth 900 mm PNC 206335
- Door for open base cupboard PNC 206342
- Filter for fryer oil collection basin for 15lt, 18lt, 23lt free standing fryers PNC 206359
- Base support for feet or wheels - 800mm (EVO700/900) PNC 206367
- Base support for feet/wheels (lateral) for 23lt fryers and pastacookers and refrigerated bases (900) PNC 206372
- Chimney grid net, 400mm PNC 206400
- 2 half baskets for 18/23lt fryers with front hook PNC 927200
- 1 full basket for 18/23lt fryers with front hook PNC 927201
- 2 half size baskets for 18/23lt well fryers PNC 927223
- 1 full size basket for 18/23lt well fryers PNC 927226
- Unclogging rod for 23lt fryers drainage pipe PNC 927227
- Deflector for floured products for the 23lt fryer PNC 960645

Front

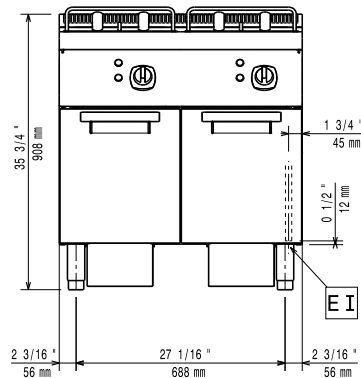

Top

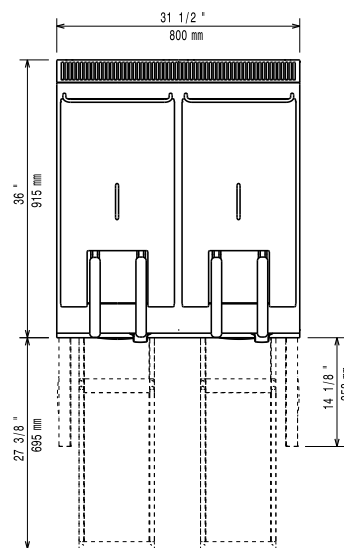

EI = Electrical connection
EQ = Equipotential screw

Side

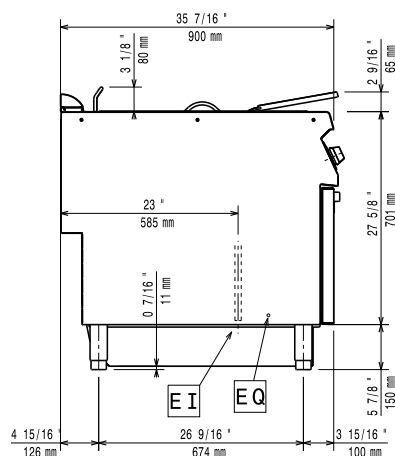

Electric

Supply voltage:
392090 (Z9FREH2JF0) 400 V/3N ph/50/60 Hz
Total Watts: 36 kW

Key Information:

Usable well dimensions (width): 340 mm
Usable well dimensions (height): 575 mm
Usable well dimensions (depth): 400 mm
Well capacity: 21 lt MIN; 23 lt MAX
Thermostat Range: 105 °C MIN; 185 °C MAX
Net weight: 115 kg
Shipping weight: 116 kg
Shipping height: 1090 mm
Shipping width: 1020 mm
Shipping depth: 860 mm
Shipping volume: 0.96 m³

If appliance is set up or next to or against temperature sensitive furniture or similar, a safety gap of approximately 150 mm should be maintained or some form of heat insulation fitted.