

Modular Cooking Range Line EVO900 4 Electric Infrared Cooking Top

ITEM # _____

MODEL # _____

NAME # _____

SIS # _____

AIA # _____



Modular Cooking Range Line

EVO900 4 Electric Infrared Cooking Top

392045 (Z9IREH4000) 4-zone (3,4 kW each) electric infrared cooking top

392170 (Z9IREH400N) 4-zone (3,4 kW each) electric infrared cooking top

Short Form Specification

Item No. _____

Glass ceramic cooking surface 6 mm thick, with 4 concentric circular heating zones. Infrared top surface with seamless transition between individual heating zones. Body and work top of unit entirely in stainless steel with Scotch Brite finish. Extra strength work top in heavy duty 2 mm stainless steel. Right-angled side edges to allow flush-fitting junction between units.

Main Features

- Ceramic glass top cooking surface with 4 infrared heating zones 6 mm thick.
- The circular concentric heating sections measuring from 180 to 300 mm give uniform heat also to the largest pan.
- The cooking top is sealed to prevent infiltration inside the unit.
- Warning light to indicate residual surface heat.
- Immediate heat transfer from cooking top to pan.
- Low heat dissipation to the kitchen.
- Energy regulation of each zone.
- The smooth glass-ceramic surface can be quickly and easily cleaned, thus providing maximum hygiene.
- IPX5 water protection.

Construction

- All exterior panels in Stainless Steel with Scotch Brite finishing.
- AISI 304 stainless steel worktop, 2mm thick.
- Model has right-angled side edges to allow flush fitting joints between units, eliminating gaps and possible dirt traps.
- Unit is 900mm deep to give a larger working surface area.

APPROVAL: _____

Optional Accessories

- Junction sealing kit PNC 206086
- 4 wheels, 2 swivelling with brake (EVO700/900). It is mandatory to install with base supports for feet/wheels. PNC 206135
- Support for bridge type installation, 800 mm PNC 206137
- Support for bridge type installation, 1000 mm PNC 206138
- Support for bridge type installation, 1200 mm PNC 206139
- Support for bridge type installation, 1400 mm PNC 206140
- Support for bridge type installation, 1600 mm PNC 206141
- Side handrail for right/left hand PNC 206165
- Frontal handrail 400 mm PNC 206166
- Frontal handrail 800 mm PNC 206167
- Large handrail (portioning shelf) 400 mm PNC 206185
- Large handrail (portioning shelf) 800 mm PNC 206186
- Frontal handrail 1200 mm PNC 206191
- Frontal handrail 1600 mm PNC 206192
- Water column with swivel arm (water column extension not included) PNC 206289
- Water column extension PNC 206290
- Chimney upstand, 800 mm PNC 206304
- 2 side covering panels, height 250 mm, depth 900 mm PNC 206321
- Base support for feet or wheels - 800mm (EVO700/900) PNC 206367

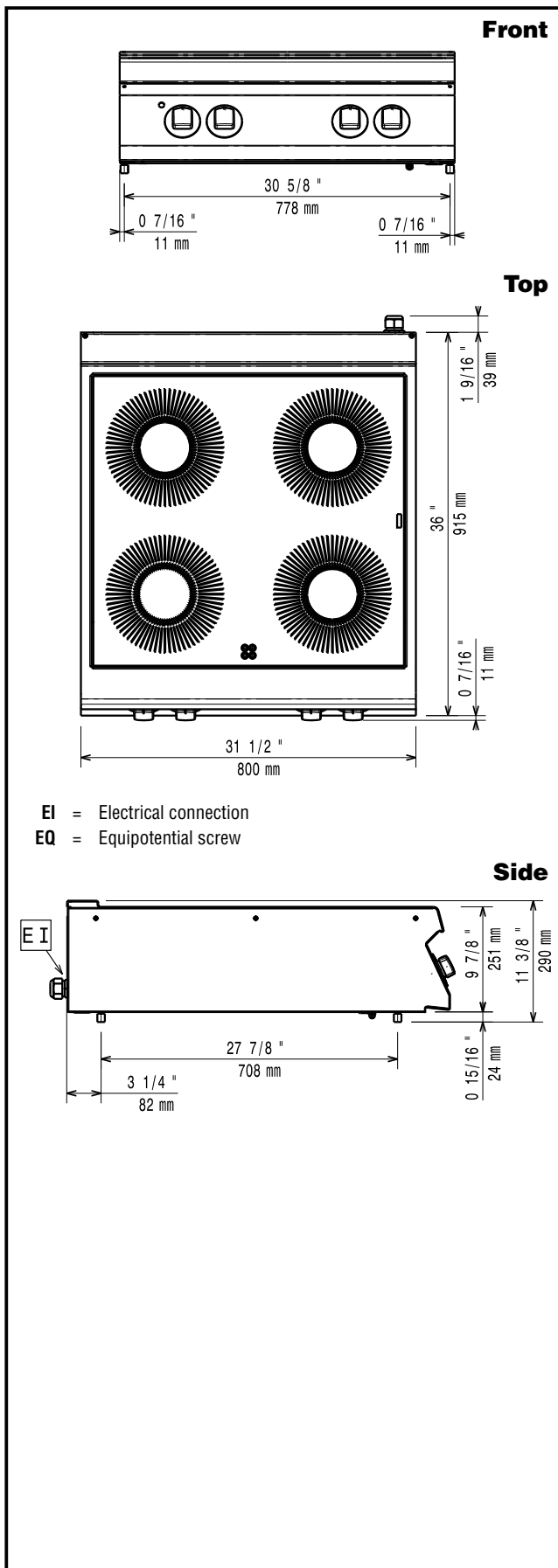

Electric

| | |
|------------------------|----------------------|
| Supply voltage: | |
| 392045 (Z9IREH4000) | 400 V/3N ph/50/60 Hz |
| 392170 (Z9IREH400N) | 230 V/3 ph/50/60 Hz |
| Total Watts: | 13.6 kW |

Key Information:

| | |
|---------------------------------|---------------------|
| Front Plates Power: | 3.4 - 3.4 kW |
| Back Plates Power: | 3.4 - 3.4 kW |
| Front Plates dimensions: | Ø 300 Ø 300 |
| Back Plates dimensions: | Ø 300 Ø 300 |
| Net weight: | 69 kg |
| Shipping weight: | 89 kg |
| Shipping height: | 540 mm |
| Shipping width: | 1020 mm |
| Shipping depth: | |
| 392045 (Z9IREH4000) | 860 mm |
| 392170 (Z9IREH400N) | 900 mm |
| Shipping volume: | |
| 392045 (Z9IREH4000) | 0.47 m ³ |
| 392170 (Z9IREH400N) | 0.5 m ³ |

If appliance is set up or next to or against temperature sensitive furniture or similar, a safety gap of approximately 150 mm should be maintained or some form of heat insulation fitted.