

**Modular Cooking Range Line
EVO900 4-Electric Hot Plate
Range on Electric Oven**

ITEM # _____

MODEL # _____

NAME # _____

SIS # _____

AIA # _____



Modular Cooking Range Line

EVO900 4-Electric Hot Plate Range on Electric Oven

- | | |
|---------------------|--|
| 392041 (Z9ECEH4QE0) | 4-hot square plates (4 kW each) electric range on electric oven (6 kW) - 400 V |
| 392167 (Z9ECEH4QEN) | 4-hot square plates (4 kW each) electric range on electric oven (6 kW) - 230V |

Short Form Specification

Item No. _____

To be installed on stainless steel feet with height adjustment up to 50 mm. Four 4 kW square cast-iron hot plates hermetically sealed to the one-piece top. Oven chamber with 3 levels of runners to accommodate 2/1 GN shelves (2 steam pans). Ribbed, cast-iron oven base plate. Exterior panels of unit in stainless steel with Scotch Brite finish. Extra strength work top in heavy duty 2 mm stainless steel. Right-angled side edges to allow flush-fitting junction between units.

Main Features

- Unit to be mounted on stainless steel feet with height adjustment up to 50 mm. Unit can be easily mounted on cantilever systems.
- The four 4kW electric cast-iron hot plates are hermetically sealed to the one piece top and are featured with safety thermostat.
- Base compartment consists of an electric standard oven with 40 mm thick oven door for heat insulation, positioned beneath the base plate.
- Oven chamber with 3 levels of runners to accommodate 2/1 GN shelves (2 steam pans).
- Ribbed cast iron oven base plate.
- Oven to feature separate thermostats for top and bottom elements. Thermostat temperature adjustable from 110°C to 285°C.
- The special design of the control knob system guarantees against water infiltration.
- IPX5 water protection.

Construction

- All exterior panels in Stainless Steel with Scotch Brite finishing.
- AISI 304 stainless steel worktop, 2mm thick.
- Model has right-angled side edges to allow flush fitting joints between units, eliminating gaps and possible dirt traps.
- Unit is 900mm deep to give a larger working surface area.

APPROVAL: _____

Included Accessories

- 1 of GN2/1 chrome grid for static oven PNC 164250

Optional Accessories

- GN2/1 chrome grid for static oven PNC 164250
- 2 cast iron plate bars for electric cooking top PNC 206056
- Junction sealing kit PNC 206086
- 4 wheels, 2 swivelling with brake (EVO700/900). It is mandatory to install with base supports for feet/wheels. PNC 206135
- Flanged feet kit PNC 206136
- Frontal kicking strip for concrete installation, 800 mm PNC 206148
- Frontal kicking strip for concrete installation, 1000 mm PNC 206150
- Frontal kicking strip for concrete installation, 1200 mm PNC 206151
- Frontal kicking strip for concrete installation, 1600 mm PNC 206152
- Pair of side kicking strips (concrete installation) PNC 206157
- Side handrail for right/left hand PNC 206165
- Frontal handrail 400 mm PNC 206166
- Frontal handrail 800 mm PNC 206167
- Frontal kicking strip, 800 mm PNC 206176
- Frontal kicking strip, 1000 mm PNC 206177
- Frontal kicking strip, 1200 mm PNC 206178
- Frontal kicking strip, 1600 mm PNC 206179
- Pair of side kicking strips PNC 206180
- 2 panels for service duct (single installation) PNC 206181
- Large handrail (portioning shelf) 400 mm PNC 206185
- Large handrail (portioning shelf) 800 mm PNC 206186
- Frontal handrail 1200 mm PNC 206191
- Frontal handrail 1600 mm PNC 206192
- 2 panels for service duct (back to back installation) PNC 206202
- 4 feet for concrete installation (not for 900 line freestanding grill) PNC 206210
- Water column with swivel arm (water column extension not included) PNC 206289
- Water column extension PNC 206290
- Chimney upstand, 800 mm PNC 206304
- 2 side covering panels, height 700 mm, depth 900 mm PNC 206335
- Base support for feet or wheels - 800mm (EVO700/900) PNC 206367
- Chimney grid net, 400mm PNC 206400

Front

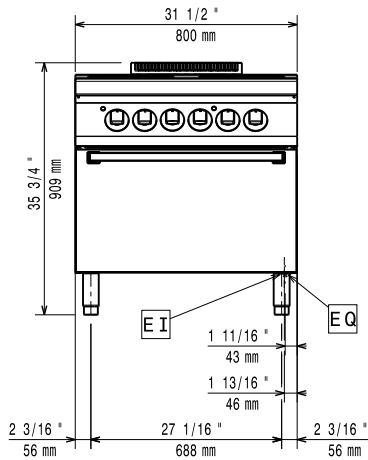

Top

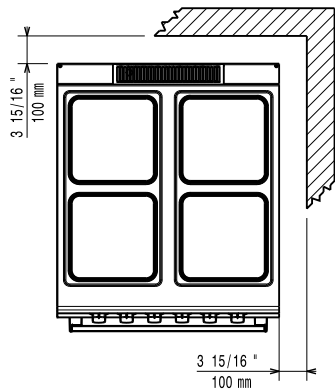

EI = Electrical connection
EQ = Equipotential screw

Side

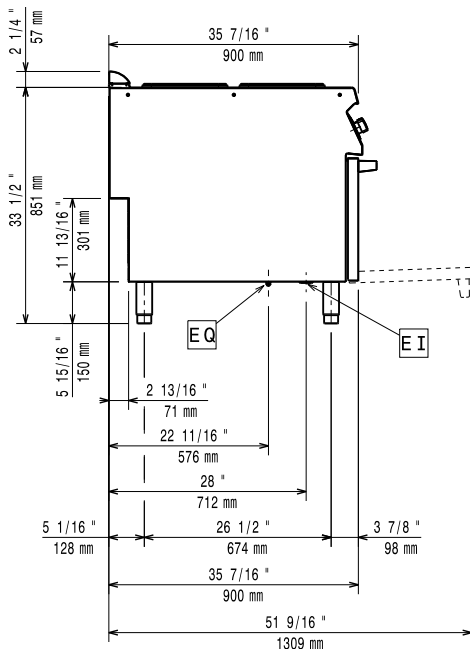

Electric

Supply voltage:

392041 (Z9ECEH4QE0)	400 V/3 ph/50/60 Hz
392167 (Z9ECEH4QEN)	230 V/3 ph/50/60 Hz

Electrical power:

22 kW

Total Watts:

22 kW

Oven Heat Input:

6 kW

Key Information:

Front Plates Power:	4 - 4 kW
Back Plates Power:	4 - 4 kW
Front Plates dimensions:	300x300 300x300
Back Plates dimensions:	300x300 300x300
Oven working Temperature:	110 °C MIN; 285 °C MAX
Oven Cavity Dimensions (width):	575 mm
Oven Cavity Dimensions (height):	300 mm
Oven Cavity Dimensions (depth):	700 mm
External dimensions, Height:	850 mm
External dimensions, Width:	800 mm
External dimensions, Depth:	900 mm
Net weight:	145 kg
Shipping weight:	
392041 (Z9ECEH4QE0)	140 kg
392167 (Z9ECEH4QEN)	170 kg
Shipping height:	
392041 (Z9ECEH4QE0)	1080 mm
392167 (Z9ECEH4QEN)	1120 mm
Shipping width:	1020 mm
Shipping depth:	860 mm
Shipping volume:	
392041 (Z9ECEH4QE0)	0.95 m ³
392167 (Z9ECEH4QEN)	0.98 m ³

If appliance is set up or next to or against temperature sensitive furniture or similar, a safety gap of approximately 150 mm should be maintained or some form of heat insulation fitted.