

Modular Cooking Range Line EVO900 Electric Multifunctional Cooker with compound bottom

ITEM # _____

MODEL # _____

NAME # _____

SIS # _____

AIA # _____



Modular Cooking Range Line

EVO900 Electric Multifunctional Cooker with compound bottom

392151 (Z9MFEHDIO0)

22-lt electric multifunctional
cooker with compound
cooking surface

Short Form Specification

Item No. _____

Incoloy armoured heating elements to guarantee heat uniformity. To be installed on 50 mm high feet for cleaning ease. Well to have rounded corners and cooking surface in compound steel (a 3mm layer of 316 AISI stainless steel on top of a 12mm layer of mild steel). Exterior panels of unit in stainless steel with Scotch Brite finish.

Main Features

- Multi purpose cooking appliance that can be used to shallow fry, cook liquids or even as a bain marie. Unit can be used for sautéing, poaching, steaming, simmering, stewing, braising, boiling and preparing white sauces.
- Well cooking surface made in compound steel (a 3mm layer of 316 AISI stainless steel on top of a 12mm layer of mild steel) for optimum grilling results.
- The stainless steel well to have rounded corners to facilitate cleaning.
- Bottom temperature control is precisely set by a thermostat on the control panel.
- Temperature can be set from 120 °C to 300 °C.
- Uniform temperature distribution over the whole base.
- Short heat-up time of the empty pan.
- Incoloy armoured heating elements for better thermic distribution.
- Thermostatic control and energy regulator to reduce energy fluctuation.
- The special design of the control knob system guarantees against water infiltration.

Construction

- All exterior panels in Stainless Steel with Scotch Brite finishing.

APPROVAL: _____

Included Accessories

- 1 of Scraper for smooth plate for fry tops PNC 164255

Optional Accessories

- Scraper for smooth plate for fry tops PNC 164255
- Junction sealing kit PNC 206086
- 4 wheels, 2 swivelling with brake (EVO700/900). It is mandatory to install with base supports for feet/wheels. PNC 206135
- Flanged feet kit PNC 206136
- Frontal kicking strip for concrete installation, 800 mm PNC 206148
- Frontal kicking strip for concrete installation, 1000 mm PNC 206150
- Frontal kicking strip for concrete installation, 1200 mm PNC 206151
- Frontal kicking strip for concrete installation, 1600 mm PNC 206152
- Pair of side kicking strips (concrete installation) PNC 206157
- Side handrail for right/left hand PNC 206165
- Frontal handrail 400 mm PNC 206166
- Frontal handrail 800 mm PNC 206167
- Frontal kicking strip, 800 mm PNC 206176
- Frontal kicking strip, 1000 mm PNC 206177
- Frontal kicking strip, 1200 mm PNC 206178
- Frontal kicking strip, 1600 mm PNC 206179
- Pair of side kicking strips PNC 206180
- 2 panels for service duct (single installation) PNC 206181
- Large handrail (portioning shelf) 400 mm PNC 206185
- Large handrail (portioning shelf) 800 mm PNC 206186
- Frontal handrail 1200 mm PNC 206191
- Frontal handrail 1600 mm PNC 206192
- 2 panels for service duct (back to back installation) PNC 206202
- 4 feet for concrete installation (not for 900 line freestanding grill) PNC 206210
- Central support for installation of drawers and grid supports for open base cupboards PNC 206245
- Water column with swivel arm (water column extension not included) PNC 206289
- Chimney upstand, 800 mm PNC 206304
- 2 side covering panels, height 700 mm, depth 900 mm PNC 206335
- Door for open base cupboard PNC 206342
- Base support for feet or wheels - 800mm (EVO700/900) PNC 206367
- Lid for 22lt multifunctional cooker PNC 921690

Modular Cooking Range Line EVO900 Electric Multifunctional Cooker with compound bottom

Front

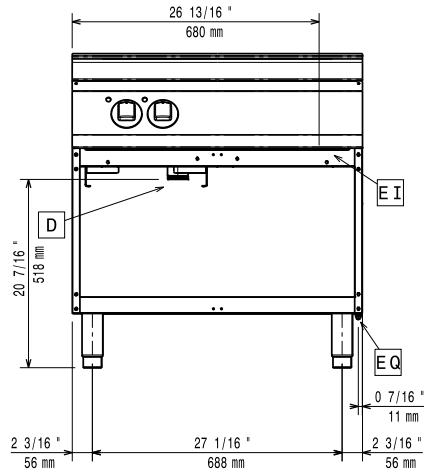

Top

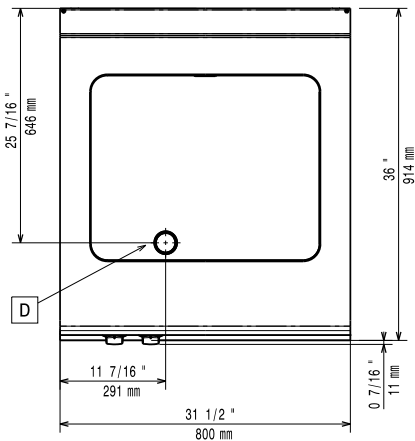

- EI = Electrical connection
- EQ = Equipotential screw
- F = Fumes outlet
- V = Air vents

Side

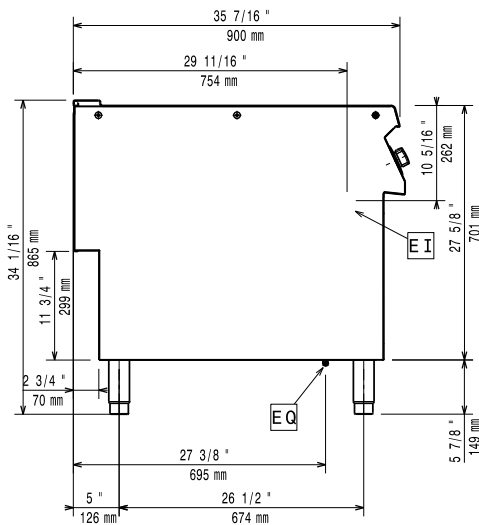

Electric

Supply voltage:

392151 (Z9MFEHD100) 400 V/3N ph/50/60 Hz

Total Watts:

10 kW

Key Information:

Cooking surface width: 630 mm

Cooking surface depth: 510 mm

Cooking Well Height: 70 mm

Working Temperature MIN: 120 °C

Working Temperature MAX: 300 °C

Net weight: 115 kg

Shipping weight: 130 kg

Shipping height: 1120 mm

Shipping width: 1020 mm

Shipping depth: 860 mm

Shipping volume: 0.98 m³

If appliance is set up or next to or against temperature sensitive furniture or similar, a safety gap of approximately 150 mm should be maintained or some form of heat insulation fitted.