

## Modular Cooking Range Line EVO900 Electric Pasta Cooker, 2 Wells, 40 litres

ITEM # \_\_\_\_\_

MODEL # \_\_\_\_\_

NAME # \_\_\_\_\_

SIS # \_\_\_\_\_

AIA # \_\_\_\_\_



### Modular Cooking Range Line EVO900 Electric Pasta Cooker, 2 Wells, 40 litres

392127 (Z9PCEH2MF0)

40+40-lt electric pasta cooker  
with 2 wells

### Short Form Specification

#### Item No. \_\_\_\_\_

Infrared heating system. Constant starch removal during the cooking process. The 40 liter tanks are pressed in 316-L type Stainless steel to protect against corrosion. Safety thermostat and electromechanical sensor prevent the machine from working without water. Height adjustable feet in stainless steel. Exterior panels in stainless steel. Worktop in 20/10, stainless steel. Right angled side edges eliminate gaps and possible dirt traps between units.

### Main Features

- In addition to cooking pasta, the appliance can be used for noodles of every kind, rice, dumplings and vegetables.
- Unit to have infrared heating system positioned beneath the base of the well.
- Water basin in 316-L type Stainless steel.
- Water basin is seamlessly welded into the top of the appliance.
- Provided with integrated drip zone on which baskets can be placed for draining purposes.
- Automatic starch removal function during cooking: improved water quality over time.
- Automatic low-water level shut-off: no accidental overheating.
- Easy-to-use control panel.
- Continuous water filling regulated through a manual water tap.
- Large drain with manual ball-valve for fast emptying of well.
- **ESD** available as accessory (installed separately): energy saving device uses heat produced by water drained through the overflow to pre-heat tap-in water up to 60°C, for constant water boiling.
- **EnergyControl**: unique feature for fine power adjustment to control boiling level and optimize energy consumption.
- All major compartments located in front of unit for ease of maintenance.
- **Automatic lifting system** (optional accessory): 200mm wide unit with three stainless steel basket supports, holding one GN 1/3 basket each, to be placed on either or both sides of machine to provide automatic lifting for six small portion baskets (to be ordered separately). Possibility to memorize nine cooking times through digital control.
- IPX5 water resistance certification.
- The special design of the control knob system guarantees against water infiltration.
- One piece pressed 2 mm work top in Stainless steel.
- Unit delivered with four 50 mm legs in stainless steel as standard (all round Stainless steel kick plates as option).
- 40 liters water basins.

### Construction

- All exterior panels in Stainless Steel with Scotch Brite finishing.
- Model has right-angled side edges to allow flush fitting joints between units, eliminating gaps and possible dirt traps.

APPROVAL: \_\_\_\_\_

### Included Accessories

- 2 of Door for open base cupboard PNC 206342

### Optional Accessories

- Junction sealing kit PNC 206086
- 4 wheels, 2 swivelling with brake (EVO700/900). It is mandatory to install with base supports for feet/wheels. PNC 206135
- Flanged feet kit PNC 206136
- Frontal kicking strip for concrete installation, 800 mm PNC 206148
- Frontal kicking strip for concrete installation, 1000 mm PNC 206150
- Frontal kicking strip for concrete installation, 1200 mm PNC 206151
- Frontal kicking strip for concrete installation, 1600 mm PNC 206152
- Pair of side kicking strips (concrete installation) PNC 206157
- Side handrail for right/left hand PNC 206165
- Frontal handrail 400 mm PNC 206166
- Frontal handrail 800 mm PNC 206167
- Frontal kicking strip, 800 mm PNC 206176
- Frontal kicking strip, 1000 mm PNC 206177
- Frontal kicking strip, 1200 mm PNC 206178
- Frontal kicking strip, 1600 mm PNC 206179
- Pair of side kicking strips PNC 206180
- 2 panels for service duct (single installation) PNC 206181
- Large handrail (portioning shelf) 400 mm PNC 206185
- Large handrail (portioning shelf) 800 mm PNC 206186
- Lid and lid holder for 40lt pasta cookers PNC 206190
- Frontal handrail 1200 mm PNC 206191
- Frontal handrail 1600 mm PNC 206192
- 2 panels for service duct (back to back installation) PNC 206202
- 4 feet for concrete installation (not for 900 line freestanding grill) PNC 206210
- Set of ergonomic baskets for 40lt pasta cookers PNC 206233
- 1 ergonomic basket for 40lt pasta cooker PNC 206237
- False bottom for 40lt pasta cooker square baskets PNC 206238
- Water column with swivel arm (water column extension not included) PNC 206289
- Chimney upstand, 800 mm PNC 206304
- 2 side covering panels, height 700 mm, depth 900 mm PNC 206335
- Door for open base cupboard PNC 206342
- Energy saving device for pasta cookers PNC 206344
- Automatic programmable basket lifting system for 40lt pasta cookers, 3 lifters PNC 206355
- Base support for feet or wheels - 800mm (EVO700/900) PNC 206367
- Chimney grid net, 400mm PNC 206400
- 3x1/3GN baskets for 40lt pasta cookers PNC 927210
- 2x1/2GN baskets for 40lt pasta cookers PNC 927211
- 3 round baskets diam. 181 mm for 40lt pasta cookers (927219 must be ordered together) PNC 927212
- 6 round baskets for 40lt pasta cookers (927219 must be ordered together) PNC 927213
- 1x1/1GN basket for 40lt pasta cookers PNC 927216

- Grid support for 40lt pasta cooker round baskets PNC 927219
- Upper support frame to hold 6 round baskets for 40lt pasta cookers (alternative to 927219 for 6 round baskets) PNC 960644

## Modular Cooking Range Line EVO900 Electric Pasta Cooker, 2 Wells, 40 litres

### Front

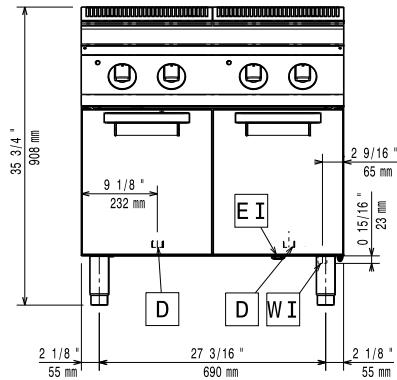

### Top

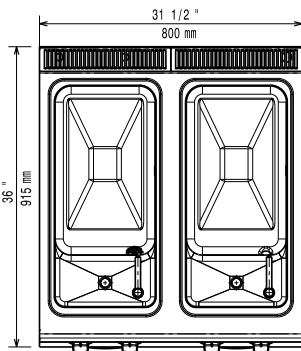

D = Drain  
EI = Electrical connection  
EQ = Equipotential screw

### Side

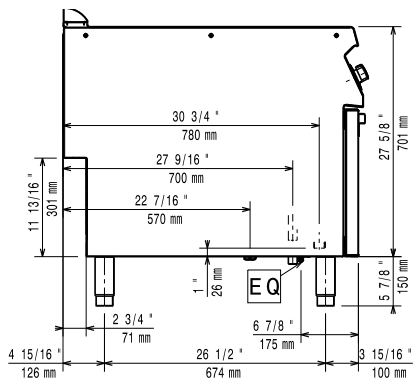

### Electric

#### Supply voltage:

392127 (Z9PCEH2MF0) 400 V/3N ph/50/60 Hz

#### Electrical power:

20 kW

#### Total Watts:

20 kW

### Water:

#### Drain "D":

1"

#### Incoming Cold/hot Water line size:

3/4"

#### Total hardness:

5-50 ppm

*Electrolux recommends the use of treated water, based on testing of specific water conditions.*

Please refer to user manual for detailed water quality information.

### Key Information:

Usable well dimensions (width):	300 mm
Usable well dimensions (height):	260 mm
Usable well dimensions (depth):	520 mm
Well Capacity (MAX):	40 lt MAX
Net weight:	115 kg
Shipping weight:	102 kg
Shipping height:	1120 mm
Shipping width:	1020 mm
Shipping depth:	860 mm
Shipping volume:	0.98 m <sup>3</sup>

If appliance is set up or next to or against temperature sensitive furniture or similar, a safety gap of approximately 150 mm should be maintained or some form of heat insulation fitted.