

## Modular Cooking Range Line EVO900 Electric Chip Scuttle

ITEM # \_\_\_\_\_

MODEL # \_\_\_\_\_

NAME # \_\_\_\_\_

SIS # \_\_\_\_\_

AIA # \_\_\_\_\_



### Modular Cooking Range Line EVO900 Electric Chip Scuttle

392098 (Z9CSPDC000)

Electric chip scuttle with 1 well  
and 1/1 GN container

### Short Form Specification

Item No. \_\_\_\_\_

Heating via infrared heating elements positioned on the back of the unit. Perforated false bottom GN 1/1 specially shaped for easier food collection. One piece pressed worktop in stainless steel. Easy to use control panel with ON/OFF switch. Exterior panels in stainless steel. Design of control knobs protects against water infiltration.

### Main Features

- Typically used in combination with a fryer to allow fried portions to drip excess oil into the well basin.
- The appliance is used to keep servings warm until ready to be served to customer.
- Unit to have infrared heating elements positioned on the back of the unit to increase holding time.
- Well able to contain 1/1 GN container with a maximum height of 150 mm.
- Easy-to-use control panel.
- Unit supplied with a perforated GN 1/1 false bottom specially shaped for easier food collection.
- One-piece pressed working top in 2mm stainless steel with Scotch Brite finish to facilitate cleaning.
- All major compartments located in front of unit for ease of maintenance.
- IPX5 water resistance certification.
- The special design of the control knob system guarantees against water infiltration.

### Construction

- All exterior panels in Stainless Steel with Scotch Brite finishing.
- Model has right-angled side edges to allow flush fitting joints between units, eliminating gaps and possible dirt traps.
- Unit is 900mm deep to give a larger working surface area.

APPROVAL: \_\_\_\_\_

**Optional Accessories**

- Junction sealing kit PNC 206086
- 4 wheels, 2 swivelling with brake (EVO700/900). It is mandatory to install with base supports for feet/wheels. PNC 206135
- Support for bridge type installation, 800 mm PNC 206137
- Support for bridge type installation, 1000 mm PNC 206138
- Support for bridge type installation, 1200 mm PNC 206139
- Support for bridge type installation, 1400 mm PNC 206140
- Support for bridge type installation, 1600 mm PNC 206141
- Support for bridge type installation, 400 mm PNC 206154
- Side handrail for right/left hand PNC 206165
- Frontal handrail 400 mm PNC 206166
- Frontal handrail 800 mm PNC 206167
- Large handrail (portioning shelf) 400 mm PNC 206185
- Large handrail (portioning shelf) 800 mm PNC 206186
- Frontal handrail 1200 mm PNC 206191
- Frontal handrail 1600 mm PNC 206192
- Water column with swivel arm (water column extension not included) PNC 206289
- Chimney upstand, 400 mm PNC 206303
- 2 side covering panels, height 250 mm, depth 900 mm PNC 206321
- Base support for feet or wheels - 400mm (EVO700/900) PNC 206366

**Front**

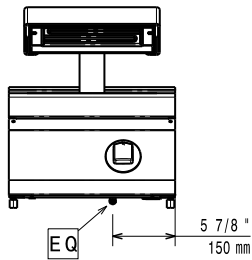

**Top**

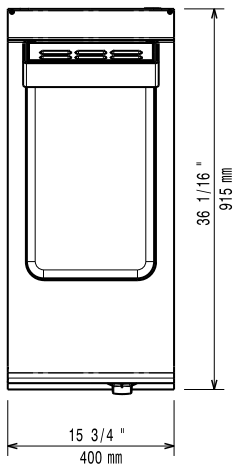

EI = Electrical connection

**Side**

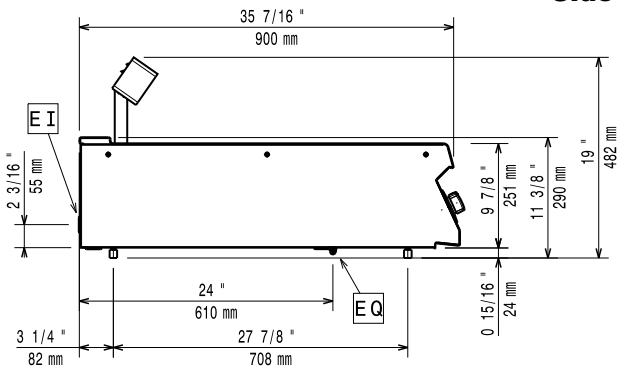

**Electric**

Supply voltage:	
392098 (Z9CSPDC000)	230 V/1N ph/50/60 Hz
Electrical power:	1 kW
Total Watts:	1 kW

**Key Information:**

Usable well dimensions (width):	306 mm
Usable well dimensions (height):	156 mm
Usable well dimensions (depth):	510 mm
Net weight:	28 kg
Shipping weight:	30 kg
Shipping height:	660 mm
Shipping width:	460 mm
Shipping depth:	1020 mm
Shipping volume:	0.31 m <sup>3</sup>

If appliance is set up or next to or against temperature sensitive furniture or similar, a safety gap of approximately 150 mm should be maintained or some form of heat insulation fitted.