

**Modular Cooking Range Line
EVO900 Half Module Electric
Fry Top, Mild Steel**

ITEM # _____

MODEL # _____

NAME # _____

SIS # _____

AIA # _____



Modular Cooking Range Line

**EVO900 Half Module Electric Fry Top,
Mild Steel**

392067 (Z9FTEDHS00)	Electric fry top with smooth mild steel horizontal plate, splashback and scraper included, half module
392171 (Z9FTEDHS0N)	Electric fry top with smooth horizontal plate, splashback and scraper included
392068 (Z9FTEDSR00)	Electric fry top with ribbed mild steel sloped plate, thermostatic control, splashback and scraper included, half module
392172 (Z9FTEDSR0N)	Electric fry top with ribbed sloped horizontal plate, splashback and scraper included

Short Form Specification

Item No. _____

Smooth cooking surface in mild steel. To be installed on open base installations, bridging supports or cantilever systems. Removable drawer below the cooking surface for the collection of grease and fat. Body and work top of unit entirely in stainless steel with Scotch Brite finish. Extra strength work top in heavy duty 2 mm stainless steel. Right-angled side edges to allow flush-fitting junction between units.

Main Features

- Unit to be mounted on open base cupboards, bridging supports or cantilever systems.
- Cooking surface in 15mm thick mild steel for optimum grilling results.
- Large drain hole on cooking surface permits the draining of fat into large 1 liter collector placed under the cooking surface.
- Electric elements in incoloy positioned under the cooking plate.
- Safety thermostat and thermostatic control.
- Stainless steel high splash guards on the rear and sides of cooking surface. Splash guards can be easily removed for cleaning and are dishwasher-safe.
- Scrapers with smooth or ribbed blades included as standard.
- The special design of the control knob system guarantees against water infiltration.
- IPX5 water protection.

Construction

- Cooking surface to be completely smooth or completely ribbed.
- All exterior panels in Stainless Steel with Scotch Brite finishing.
- AISI 304 stainless steel worktop, 2mm thick.
- Model has right-angled side edges to allow flush fitting joints between units, eliminating gaps and possible dirt traps.
- Unit is 900mm deep to give a larger working surface area.

APPROVAL: _____

Included Accessories

- 1 of Stopper for fry top horizontal plate (only for 392067, 392171) PNC 206296

Optional Accessories

- Scraper for smooth plate for fry tops PNC 164255
- Junction sealing kit PNC 206086
- Support for bridge type installation, 800 mm PNC 206137
- Support for bridge type installation, 1000 mm PNC 206138
- Support for bridge type installation, 1200 mm PNC 206139
- Support for bridge type installation, 1400 mm PNC 206140
- Support for bridge type installation, 1600 mm PNC 206141
- Water drain for half module fry top PNC 206153
- Support for bridge type installation, 400 mm PNC 206154
- Side handrail for right/left hand PNC 206165
- Frontal handrail 400 mm PNC 206166
- Frontal handrail 800 mm PNC 206167
- Large handrail (portioning shelf) 400 mm PNC 206185
- Large handrail (portioning shelf) 800 mm PNC 206186
- Frontal handrail 1200 mm PNC 206191
- Frontal handrail 1600 mm PNC 206192
- Water column with swivel arm (water column extension not included) PNC 206289
- Water column extension PNC 206290
- Stopper for fry top horizontal plate (only for 392067, 392171) PNC 206296
- 2 side covering panels, height 250 mm, depth 900 mm PNC 206321
- Grease/oil container kit for frytops PNC 206346
- Chimney grid net, 400mm PNC 206400
- Scraper for ribbed plate fry tops - kit includes knife blades for both smooth and ribbed surface (only for 392068, 392172) PNC 206420

Front

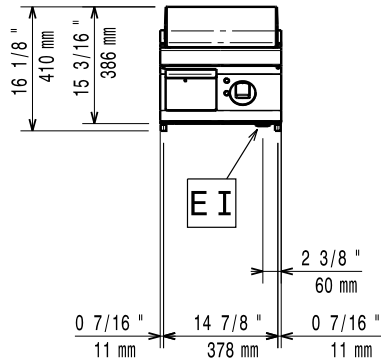

Top

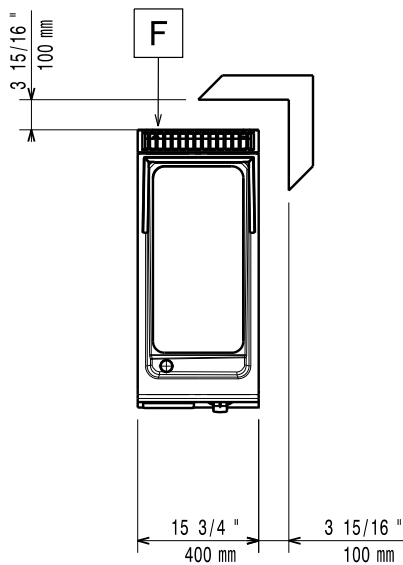

EI = Electrical connection
EQ = Equipotential screw
F = Fumes outlet

Side

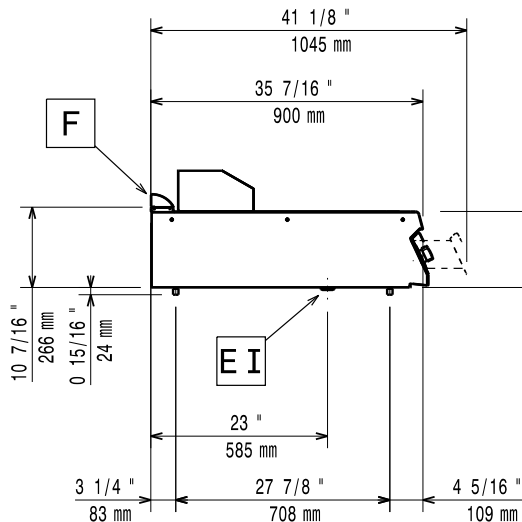

Electric

Supply voltage:

392067 (Z9FTEDHS00)	400 V/3 ph/50/60 Hz
392171 (Z9FTEDHSON)	230 V/3 ph/50/60 Hz
392068 (Z9FTEDSR00)	400 V/3 ph/50/60 Hz
392172 (Z9FTEDSRON)	230 V/3 ph/50/60 Hz

Total Watts:

7.5 kW

Key Information:

Cooking surface width:	330 mm
Cooking surface depth:	700 mm
Working Temperature MIN:	120 °C
Working Temperature MAX:	280 °C
Net weight:	55 kg
Shipping weight:	65 kg
Shipping height:	540 mm
Shipping width:	
392067 (Z9FTEDHS00)	460 mm
392171 (Z9FTEDHSON)	460 mm
392068 (Z9FTEDSR00)	460 mm
392172 (Z9FTEDSRON)	500 mm
Shipping depth:	1020 mm
Shipping volume:	
392067 (Z9FTEDHS00)	0.28 m ³
392171 (Z9FTEDHSON)	0.28 m ³
392068 (Z9FTEDSR00)	0.25 m ³
392172 (Z9FTEDSRON)	0.28 m ³

If appliance is set up or next to or against temperature sensitive furniture or similar, a safety gap of approximately 150 mm should be maintained or some form of heat insulation fitted.