

Convection Oven Electric Convection Oven, 6 GN1/1

ITEM # _____

MODEL # _____

NAME # _____

SIS # _____

AIA # _____



Convection Oven

Electric Convection Oven, 6 GN1/1

240205 (FCF61E)

6 1/1 GN grids, electric

Short Form Specification

Item No. _____

Main structure in stainless steel. Cooking chamber, grid supports, diffusers, and fan walls in stainless steel. Door with tempered glass and press-button opening and closing system. Oven chamber with rounded corners and side lighting. Flow Channel ventilation system. Heating via "Incoloy" armoured elements positioned on the convector unit. Electromechanical thermostat; temperature adjustable from 30°C to 300°C; visual display and thermometer. Timer from 0 to 120 minutes with acoustic alarm. 5-level humidity control. Functional level: base, manual. Supplied with n. 1 set of shelf guides, 60 mm pitch, for 6x1/1GN grids.

Main Features

- IPX4 water resistance certification.
- Racks can be easily removed without the need for special tools.
- Maximum temperature of 300°C.
- Food temperature probe available as accessory.
- Rapid cooling of oven cavity.
- Halogen lighting and "crosswise" pan supports allow clear and unobstructed view of the products being cooked.
- 5 Stage humidification control, to ensure perfect pastries and succulent roasts.
- Meets the requirements of CE, VDE and DVGW for safety.
- Perfect evenness: guarantees perfect distribution of heat throughout the oven cavity.

Construction

- Height adjustable feet.
- Access to all components from the front.
- Stainless steel oven cavity with rounded corners.
- External access door for electrical connections.
- All connections made on the left side below the oven.
- Integrated drain outlet.

APPROVAL: _____

Optional Accessories

- Pair of 1/1 GN grids in 304 AISI PNC 921101
- Pair of 1/2 GN pan support shelves PNC 921106
- Automatic water softener PNC 921305
- Resin sanitizer for water softener PNC 921306
- Probe for 6-10 1/1 GN ovens PNC 921702
- 1/1 GN drain pan guide kit PNC 921713
- Couple of grids GN 1/1 for whole chicken (8 per grid) PNC 922036
- Base for 6 1/1 GN oven PNC 922101
- Shelf guides for 6 1/1 GN oven base PNC 922105
- Feet for 6&10x1/1 GN and 10x2/1 GN ovens PNC 922127
- Retractable hose reel water spray unit PNC 922170
- Side external water spray unit (needs to be mounted outside and includes support for mounting to oven) PNC 922171
- Fat filter for 6 GN ovens PNC 922177
- 2 frying baskets for ovens PNC 922239
- Grid GN 1/1 for 8 whole chickens (1,2 kg each) PNC 922266
- Kit universal skewer rack and 6 short skewers for Lengthwise and Crosswise ovens PNC 922325
- Universal skewer rack PNC 922326
- Smoker for lengthwise and crosswise ovens - 4 kinds of smoker wood chips are available on request PNC 922338

Front

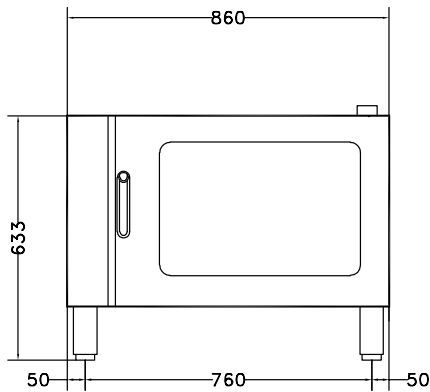

Top

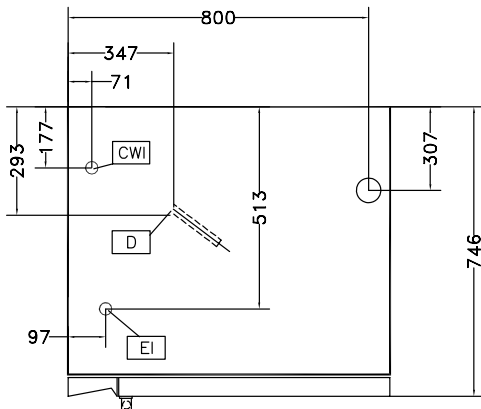

- CWI1** = Cold Water inlet 1
- CWI2** = Cold Water Inlet 2
- D** = Drain
- EI** = Electrical connection

Side

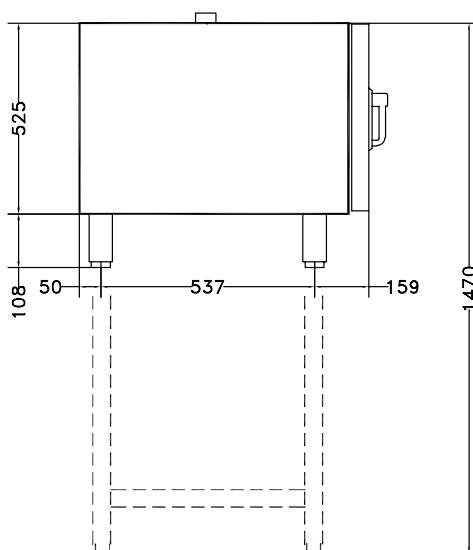

Electric

Supply voltage:
240205 (FCF61E) 400 V/3N ph/50 Hz
Electrical power: 7.7 kW

Capacity:

Shelf capacity: 6

Key Information:

External dimensions, Height: 633 mm
 External dimensions, Width: 860 mm
 External dimensions, Depth: 746 mm
 Net weight: 79.5 kg
 Functional level: Basic
 Type of grids: 1/1 Gastronorm
 Runners pitch: 60 mm
 Cooking cycles - air-convection: 300 °C
 Heating-up time (hot air cycle): 215°C / 300s.