

NPT Active
2 Door Digital Freezer, 1430lt
(-22/-15)

ITEM # _____

MODEL # _____

NAME # _____

SIS # _____

AIA # _____



NPT Active
2 Door Digital Freezer, 1430lt (-22/-15)

110787 (NPT142FF6) 2-door freezer 1430lt, -22-15°
C, digital, AISI 304

Short Form Specification

Item No. _____

Internal and external doors, front and side panels and worktop in 304 AISI stainless steel. N.2 doors and n.4x1/2 drawers. Built-in refrigeration unit. Ventilated. Refrigerant R404a. High-density expanded polyurethane foam, 50 mm in thickness, with cyclopentane injection. Digital control panel. Completely automatic defrosting and automatic evaporation of defrost water obtained by hot gas. Suitable to operate in ambient temperatures up to +43° C. Temperature range: -2+10°C. CFC and HCFC free. Feet in 304 AISI stainless steel, adjustable in height.
Supplied with n.2x1/1GN Rilsan grids and n. 6 pairs of runners.

Main Features

- Freezer model has operating temperatures that can be adjusted from -22 to -15 °C.
- Large storage area suitable to contain 2/1 GN grids or shelves on anti-tilt runners.
- Cabinet fitted with up to 75 mm thickness of cyclopentane insulation for best insulating performance with 100% environmental protection (thermal conductivity: 0,020 W/m*K).
- Automatic evaporation of the defrosting water by hot gas on the top for energy saving.
- Interior LED light to save energy and for best internal visibility.
- Internal structure with numerous charging positions available to host grids, ensuring higher net capacity and a greater storage space.
- 60 mm-thick insulation covering the evaporator can be easily removed with a single operation.
- Removable triple-chamber balloon magnetic gasket to improve insulation and reduce energy consumption.
- Large digital white-digit display with cabinet temperature display and setting, manual activation of defrost cycle and turbo frost cycle (to rapidly cool warm loads).
- Fully compliant HACCP digital control: when temperature exceeds critical limits, acoustic and visual alarms are activated. Up to two months of event are kept in memory.
- Prearranged to fit RS485 port to facilitate connection to a remote computer and integrated HACCP systems.
- The Active Defrost activates the defrost cycle only when necessary and only for the required time.
- Back to front forced air flow and removable air conveyors provide even temperature distribution and fast cooling in any conditions.
- Rilsan coated grids for improved protection.
- Tropicalized unit (43°C ambient temperature).
- This appliance is intended for use in ambient temperatures up to 40°C.

Construction

- CFC and HCFC-free insulation.
- Interior base with corners, pressed from a single sheet.
- Lockable door.
- Refrigerant type: R404a.
- Constructed from the highest quality AISI 304 Stainless steel.
- Easy access to the main components for maintenance.
- Stainless steel runners and supports easily disassembled.
- The rounded internal corners, the easily removable runners, grids and air conveyors allow for ease of cleaning and high hygiene standards.
- Door switch stops the fan when door is opened to avoid

APPROVAL: _____

cold air exiting the cell, thus saving energy.

- Anti-corrosion bottom avoids any damage that may be caused to the cabinet by aggressive detergents employed to clean the floors.

Included Accessories

- 8 of 2/1GN grey rilsan grid with 2 runners PNC 881020

Optional Accessories

- 2 stainless steel runners for refrigerated cabinets (Marine) PNC 880242
- Set of 8 GN1/1 PVC containers for fish PNC 880243
- Spacer for 670 lt and 1430 lt refrigerated cabinets PNC 880248
- Kit to fit pastry trays (400x600mm) PNC 880333
- Kit of 6 swivelling wheels, 2 with brake, diam 50 mm PNC 880340
- 1/1GN plastic container with false bottom PNC 880705
- 4 swivelling wheels (2 with brake) for refrigerators, diam 125 mm, NOT for Glass Door and remote models PNC 881002
- 2/1GN grey rilsan grid PNC 881004
- 2/1GN aisi 304 stainless steel grid PNC 881016
- 2/1GN 304 AISI stainless steel grid with 2 runners PNC 881018
- 2/1GN grey rilsan grid with 2 runners PNC 881020
- Set of 2 stainless steel runners for 670/1430lt refrigerators and freezers PNC 881021
- Pedal opening for 1430lt refrigerator PNC 881033
- 2/1GN pvc container with lid and 2 runners PNC 881039
- 2/1GN perforated shelf PNC 881042
- 1/1GN rilsan steel wire basket h=150mm PNC 881043
- 3 grey rilsan central grids for 1430lt (not for glass door) PNC 881044
- 2/1GN grey rilsan basket+2 runners h=150mm PNC 881047
- Printer for HACCP basic version (for cabinets and counters with digital control) PNC 881457

Front

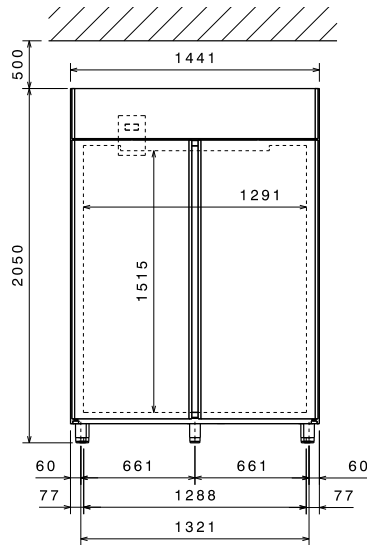

Top

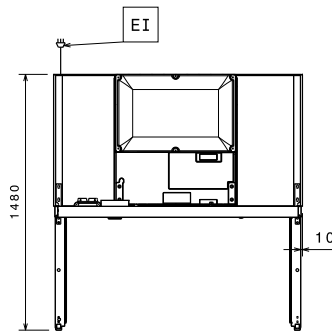

EI = Electrical connection
RI = Refrigerant Inlet
RO = Refrigerant Outlet

Side

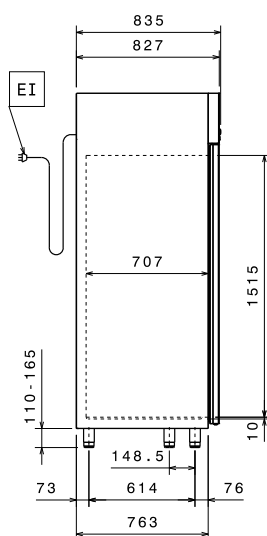

Electric

Supply voltage:
110787 (NPT142FF6) 230 V/1 ph/50 Hz
Electrical power: 0.83 kW

Key Information:

Gross capacity: 1430 lt
Net Volume: 1135 lt
Door hinges: 1 Left+1 Right
External dimensions, Height: 2050 mm
External dimensions, Width: 1441 mm
External dimensions, Depth: 837 mm
External dimensions, Depth with Doors Open: 1480 mm
Number and type of doors: 2 Full
Number and type of grids (included): 8 - GN 2/1
Type of external material: 304 AISI
Type of internal material: 304 AISI
Internal panels material: 304 AISI
Number of positions & pitch: 44; 30 mm

Refrigeration Data

Control type: Digital
Refrigerant type: R404a
Refrigeration power: 965 W
Refrigeration power at evaporation temperature: -30 °C
Refrigerant weight: 290 g
Operating temperature min.: -22 °C
Operating temperature max.: -15 °C
Operating mode: Ventilated

Product Information (EU Regulation 2015/1094)

Energy Class: D
Yearly energy consumption: 4774kWh/year
Climate class: Heavy Duty (5)
Energy Efficiency Index (EEI): 67,56