

**NPT Active
2 Door Digital Refrigerator,
1430lt (-2/+10) - Remote**

ITEM # _____

MODEL # _____

NAME # _____

SIS # _____

AIA # _____



NPT Active

**2 Door Digital Refrigerator, 1430lt
(-2/+10) - Remote**

110131 (NPT142FRR)

2-door refrigerator
1430lt, -2+10°C, digital,
remote, AISI 304

Short Form Specification

Item No. _____

Two full door refrigerator entirely constructed in 304 AISI stainless steel with bottom panel in anti-corrosive material. Large digital display featuring humidity selection button (3 preset level), cabinet temperature display and setting, manual activation of defrost cycle and turbo frost cycle (to rapidly cool warm loads). HACCP-compliant control with alarms and history. Active defrost activates only when required with automatic evaporation of defrost water. Three probes to constantly monitor the working conditions of the appliance. Optimized back to front forced air flow and removable air conveyors provide even temperature distribution and fast cooling in any conditions. Fitted with 75 mm-thick cyclopentane insulating foam. Door features lock and door microswitch to switch off the fan when the door is opened. Hidden evaporator to guarantee higher storage capacity and less corrosion problems. Remote refrigeration unit; ventilated operation; Internal LED light and internal back light. For ambient temperatures up to 43 °C. CFC and HCFC free. R134a gas in refrigeration circuit.

Supplied with n. 8x2/1GN Rilsan coated grids and n. 8 sets of 2 stainless steel grid runners. Prearranged to fit RS485 port to facilitate connection to a remote computer and integrated HACCP systems.

Main Features

- Large digital white-digit display with humidity selection button (3 preset level), cabinet temperature display and setting, manual activation of defrost cycle and turbo frost cycle (to rapidly cool warm loads).
- Fully compliant HACCP digital control: when temperature exceeds critical limits, acoustic and visual alarms are activated. Up to two months of event are kept in memory.
- Large storage area suitable to contain 2/1 GN grids or shelves on anti-tilt runners.
- Improved defrost and evaporator fan management – defrost type changes with temperature set-point: electric below +2°C while air convection defrost above +2°C, thus saving energy.
- Internal structure with numerous charging positions available to host grids, ensuring higher net capacity and a greater storage space.
- Operating temperature can be adjusted from -2 to +10 °C to suit different food storage requirements.
- Cabinet fitted with up to 75 mm thickness of cyclopentane insulation for best insulating performance with 100% environmental protection (thermal conductivity: 0,020 W/m*K).
- Removable triple-chamber balloon magnetic gasket to improve insulation and reduce energy consumption.
- 60 mm-thick insulation covering the evaporator can be easily removed with a single operation.
- Interior LED light to save energy and for best internal visibility.
- Prearranged to fit RS485 port to facilitate connection to a remote computer and integrated HACCP systems.
- The Active Defrost activates the defrost cycle only when necessary and only for the required time.
- Back to front forced air flow and removable air conveyors provide even temperature distribution and fast cooling in any conditions.
- Rilsan coated grids for improved protection.

Construction

- Constructed from the highest quality AISI 304 Stainless steel.
- Interior base with corners, pressed from a single sheet.
- The rounded internal corners, the easily removable runners, grids and air conveyors allow for ease of cleaning and high hygiene standards.
- Stainless steel runners and supports easily disassembled.
- Anti-corrosion bottom avoids any damage that may be caused to the cabinet by aggressive detergents employed to clean the floors.
- Easy access to the main components for maintenance.
- Lockable door.
- Door switch stops the fan when door is opened to avoid cold air exiting the cell, thus saving energy.

APPROVAL: _____

- Refrigerant type: R134a.
- CFC and HCFC-free insulation.
- Remote refrigeration unit to suit operating conditions.

Included Accessories

- 8 of 2/1GN grey rilsan grid with 2 runners PNC 881020

Optional Accessories

- Remote unit -2+10°C for 1430lt refrigerated cabinets PNC 880232
- 2 stainless steel runners for refrigerated cabinets (Marine) PNC 880242
- Set of 8 GN1/1 PVC containers for fish PNC 880243
- Spacer for 670 lt and 1430 lt refrigerated cabinets PNC 880248
- Kit to fit pastry trays (400x600mm) PNC 880333
- 1/1GN plastic container with false bottom PNC 880705
- 2/1GN grey rilsan grid PNC 881004
- 2/1GN aisi 304 stainless steel grid PNC 881016
- 2/1GN 304 AISI stainless steel grid with 2 runners PNC 881018
- Meat rail for 670/1430lt refrigerators with 4 hooks PNC 881019
- 2/1GN grey rilsan grid with 2 runners PNC 881020
- Set of 2 stainless steel runners for 670/1430lt refrigerators and freezers PNC 881021
- Pedal opening for 1430lt refrigerator PNC 881033
- 2/1GN pvc container with lid and 2 runners PNC 881039
- 2/1GN perforated shelf PNC 881042
- 1/1GN rilsan steel wire basket h=150mm PNC 881043
- 3 grey rilsan central grids for 1430lt (not for glass door) PNC 881044
- 2/1GN grey rilsan basket+2 runners h=150mm PNC 881047
- Printer for HACCP basic version (for cabinets and counters with digital control) PNC 881457

Front

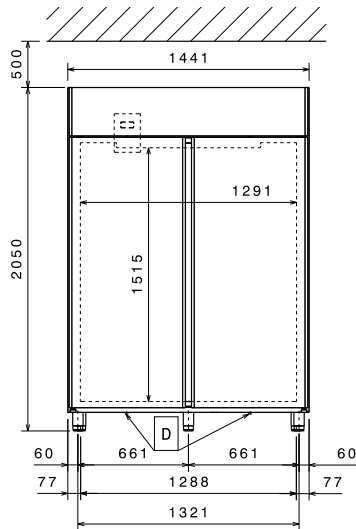

Top

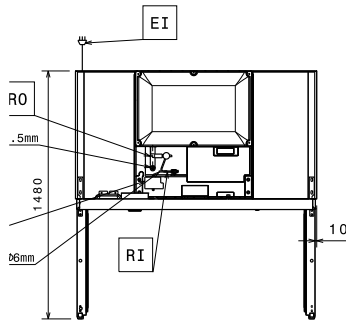

EI = Electrical connection
RI = Refrigerant Inlet
RO = Refrigerant Outlet

Side

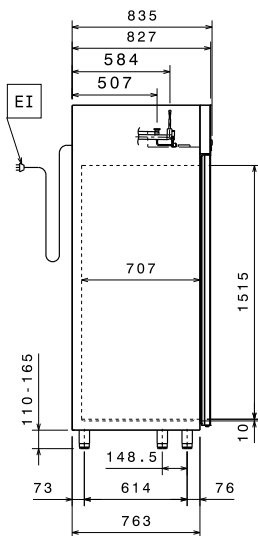

Electric

Supply voltage:
110131 (NPT142FRR) 230 V/1 ph/50 Hz
Electrical power: 0.155 kW

Key Information:

Gross capacity: 1430 lt
Door hinges: 1 Left+1 Right
External dimensions, Height: 2050 mm
External dimensions, Width: 1441 mm
External dimensions, Depth: 837 mm
External dimensions, Depth with Doors Open: 1480 mm
Number and type of doors: 2 Full
Number and type of grids (included): 8 - GN 2/1
Type of external material: 304 AISI
Type of internal material: 304 AISI
Internal panels material: 304 AISI
Number of positions & pitch: 44; 30 mm

Refrigeration Data

Control type: Digital
Refrigerant type: R134a
Suggested refrigeration power*: 458 W
Condition at evaporation temperature: -10 °C
Condition at condensation temperature: 55 °C
Condition at ambient temperature: 43 °C
Connection pipes (remote) - outlet: 9.5 mm
Connection pipes (remote) - inlet: 6 mm

*Note: Ref. Power calculated at a linear distance of 15 mt (piping)

Remote Compressor and Refrigeration Unit