

PT3 Line
2 Door Freezer Counter, 290lt
(-22/-15) - Upstand

ITEM # _____

MODEL # _____

NAME # _____

SIS # _____

AIA # _____



PT3 Line

2 Door Freezer Counter, 290lt (-22/-15) - Upstand

113178 (TRFA132A)

2-door freezer table, -22-13°C

Short Form Specification

Item No. _____

Internal and external doors, front and side panels in 304 AISI stainless steel. No worktop. N.3 doors and n.2x1/2 drawers. Built-in refrigeration unit. Ventilated. Refrigerant R404a. High-density expanded polyurethane foam, 50 mm in thickness, with cyclopentane injection. Digital control panel. Evaporator in aluminium. Completely automatic defrosting and automatic evaporation of defrost water obtained by hot gas. Suitable to operate in ambient temperatures up to +43°C. Temperature range: -2+10°C. CFC and HCFC free. Feet in 304 AISI stainless steel, adjustable in height. Pre-arranged for drain pipe.

Supplied with n.3x1/1GN Rilsan grids and n. 9 pairs of runners.

Main Features

- Adjustable temperature range from -15 °C to -22 °C to suit meat, fish and dairy storage requirements.
- Electronic microprocessor control with external digital temperature display.
- Forced air circulation for rapid cooling and an even temperature distribution.
- Raised rear upstand permits unit to be connected up against the wall for better hygiene.
- 60 mm insulation for energy saving.
- CFC and HCFC free (ecological refrigerant type: R404a, - gas in foam: cyclopentane).
- Anti-tilt runners accept GN 1/1 containers.
- Tropicalized unit (43°C ambient temperature).
- This appliance is intended for use in ambient temperatures up to 40°C.

Construction

- Constructed from AISI 304 Stainless steel throughout to meet the highest hygiene standards.
- Rounded internal corners for ease of cleaning.
- Mounted on Stainless steel legs to give 150 mm clearance for ease of cleaning the floor.
- Worktop in AISI 304 Stainless steel with a 50 mm thickness.
- Access to all components from the front.
- Developed and produced in ISO 9001 and ISO 14001 certified factory.
- Built-in compressor to suit operating conditions.

Included Accessories

- 2 of 1/1 GN grey "rilsan" grid PNC 881435

Optional Accessories

- 1/1 GN plastic container h. 100 mm, 14 lt capacity PNC 811451
- Kit integrated HACCP for digital refrigerators (IR33) PNC 880252
- 2 wheels (one with brake) PNC 880539
- 1/1 GN plastic container h. 65 mm PNC 881038
- 1/1 GN plastic container h. 150 mm PNC 881040
- 1/1 GN grey "rilsan" grid PNC 881435
- Printer for HACCP basic version (for cabinets and counters with digital control) PNC 881457
- Kit lock for refrigerated counter PNC 881499
- Kit 1 door with internal rack for refrigerated counter PNC 881508

APPROVAL: _____

Front

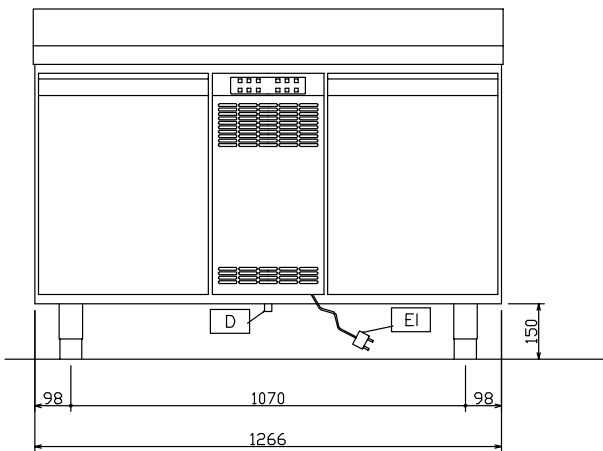

Top

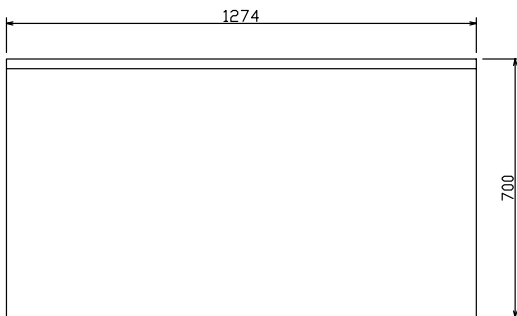

D = Drain
EI = Electrical connection

Side

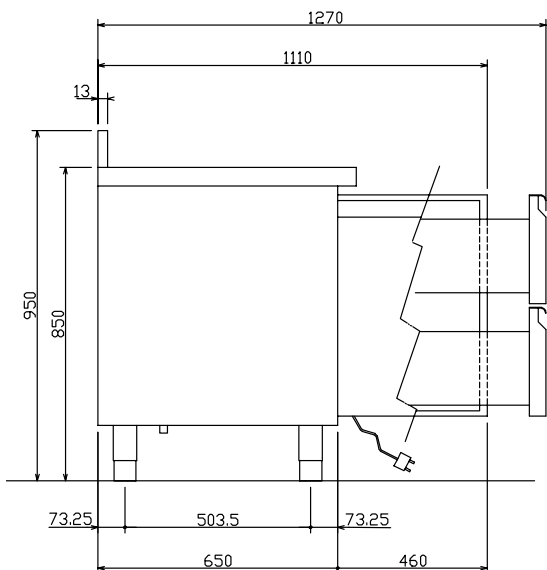

Electric

Supply voltage:
113178 (TRFA132A) 230 V/1N ph/50 Hz
Electrical power: 0.67 kW

Key Information:

Gross capacity: 290 lt
Net Volume: 157 lt
N° of doors: 2
Door hinges: 1 Left+1 Right
External dimensions, Height: 950 mm
External dimensions, Width: 1274 mm
External dimensions, Depth: 700 mm
Noise level: 60 dBA
Depth with doors open: 1110 mm
Height adjustment: -10/50 mm
Number and type of grids (included): 2 - GN 1/1
Worktop type: Stainless Steel with Splashback
Built-in Compressor and Refrigeration Unit

Refrigeration Data

Control type: Digital
Compressor power: 1 hp
Refrigerant type: R404a
Refrigeration power: 935 W
Refrigeration power at evaporation temperature: -30 °C
Refrigerant weight: 280 g
Operating temperature min.: -22 °C
Operating temperature max.: -15 °C
Operating mode: Ventilated

Product Information (EU Regulation 2015/1094)

Energy Class: g
Yearly energy consumption: 3700kWh/year
Climate class: Heavy Duty (5)
Energy Efficiency Index (EEI): 112,22