

Pizza ovens 2-deck Mechanical Electric Oven, 9x2 Pizzas (35cm)

ITEM # _____

MODEL # _____

NAME # _____

SIS # _____

AIA # _____



Pizza ovens

2-deck Mechanical Electric Oven, 9x2 Pizzas (35cm)

291092 (PODM29)

2-deck mechanical electric oven for 9x2 pizzas (diam. 35 cm)

Short Form Specification

Item No.

Front in stainless steel. Increased visibility thanks to the large and highly resistant borosilicate glass in the oven door. Separately controlled chambers in stainless steel. Cooking surface in refractory material of cordierite (20mm thick) suitable for direct cooking or with trays. Arched cooking chambers guarantee an even cooking temperature and reduce the emission of wasted heat. 12 cm thick rock wool insulation guarantees minimal heat dispersion from the oven. Internal light protected by a borosilicate glass cover which can be easily removed for replacement. Heating via armoured stainless steel elements on the top and bottom of the chamber. Heat recovery system. Vapor release vent. The control panel is not attached to the oven thus protecting the electrical components. Mechanically controlled temperature. Safety thermostat. Stand, hood and leavening cabinet available as accessories.

Main Features

- CE marked.
- Heat recovery system, which ensures a high level of cooking uniformity by limiting the heating waste during the baking cycle and allows a quick heating recovery after the loading operation.
- Special 12 cm-thick rock wool insulation, which guarantees minimal energy consumption and reduction of heat dispersion from the oven, thus limiting rise in temperature of the working environment.
- The special construction assures maximum baking uniformity. This allows to obtain a better quality pizza, eliminating the user's need for rotating the pizza, and consequently reducing the working times.
- Mechanical control with possibility to regulate the temperature of the chamber and the power of the two groups of heating elements (top and bottom) in different manner at minimum or maximum.
- Control panel completely separate from the cooking chamber, in order to ensure the correct functionality of the electric components and to ease any maintenance operations.

Construction

- Cooking chamber constructed in stainless steel. Cooking surface made of cordierite refractory material, which allow backing directly on the surface, as well as in trays.
- Fixed vapor release vent.
- Heatproof internal lighting protected by a stock-resistant covering (12V), easy to remove for replacement.
- Large-sized door in 430 AISI stainless steel, fitted with a highly resistant borosilicate glass front to increase visibility.

Optional Accessories

- Hood for 9 and 9x2-pizza (diam. 35 cm) mechanical electric oven, wide opening PNC 291102
- Stand for 9x2-pizza (diam. 35 cm) mechanical electric oven, wide opening PNC 291129

APPROVAL: _____

Front

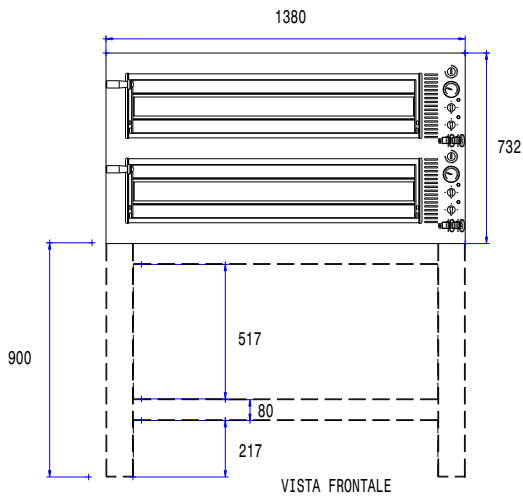

Top

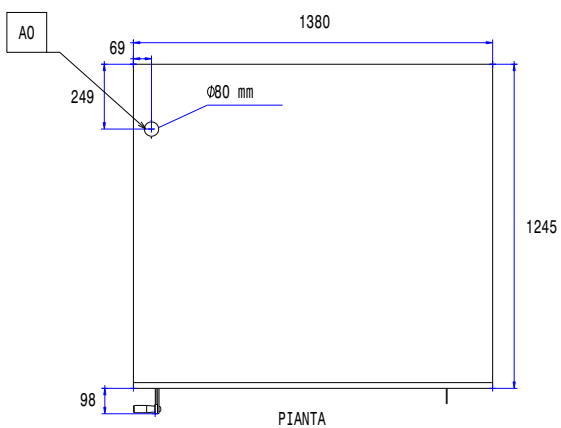

EI = Electrical connection

Side

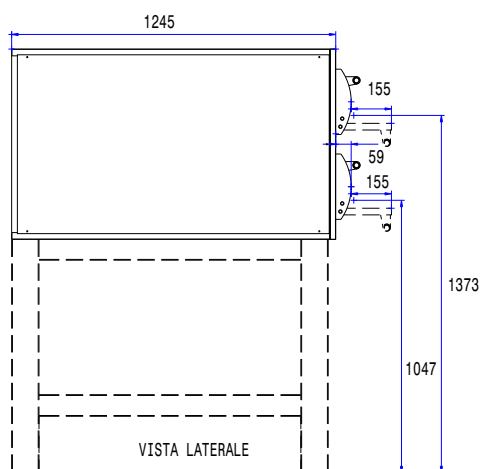

Electric

Supply voltage:
291092 (PODM29) 400 V/3N ph/50/60 Hz
Electrical power: 23.4 kW

Key Information:

External dimensions, Height: 732 mm
External dimensions, Width: 1380 mm
External dimensions, Depth: 1280 mm
Net weight: 301 kg
Shipping weight: 352 kg
Shipping height: 910 mm
Shipping width: 1390 mm
Shipping depth: 1420 mm
Cooking cycles - air-convection: 400 °C
Internal dimensions, width: 1080 mm
Internal dimensions, depth: 1080 mm
Internal dimensions, height: 145 mm