

# Catering

Depth 815 mm

Cabinet Smart 700 lt 0°+10°C 1 door

Model: **A70/1NE**

Code: **A120701001**

**Exterior/interior finishing:**

- Stainless steel AISI 304 18/10
- Back in galvanised steel

**Insulation:**

- 75 mm thickness - CFC/HCFC free

**Cover evaporator:**

- Removable in PVC

**Internal racks and slides:**

- Stainless steel AISI 304 18/10

**Inner corners:**

- Rounded corners ensuring maximum hygiene

**Feet:**

- Stainless steel AISI 304 adjustable 100-150 mm

**Door:**

- Self-closing, reversible with 105° dwell

**Door handle:**

- Integrated in PVC

**Door gasket:**

- Magnetic, easy to replace



Constructional data



• Dimensions	740×815×2085 mm
• Packing dimensions	760×850×2250 mm
• Net weight	130 Kg
• Gross capacity	700 lt
• Temperature range	0°+10°C
• Cooling capacity	368 W*
• Standard connection	230 V - 50 Hz
• Total rate	328 W - 1,8 A
• Cooling gas	R404a
• Standard equipment	N. 3 plastic coated shelves - GN2/1 Key lock
• *Evap. -10°C cond. 54,4°C	

Features

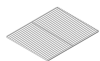

Plastic coated shelf GN 650×530 mm  
Code O221650530



Kit of 4 swivel and brake castors in stainless steel AISI 304  
Code O444000020



Pair of slides type C - 605 mm  
Code O121160520



Lighting kit 07  
Code O820700020

Accessories



Cold Line S.r.l. • Via E. Mattei, 38 • 35038 Torreglia • Padova - Italy • [www.coldline.it](http://www.coldline.it) • [info@coldline.it](mailto:info@coldline.it)

In order to constantly offer the best possible products, we reserve the right to make changes on technical specifications without incurring any obligation for equipment previously or subsequently sold.



# Catering

Depth 815 mm

# Cabinet Smart 700 lt 0°+10°C 1 door

Coldline made major investments in design research, becoming a leader in technology and innovation. Each cabinet marked with the FSSsymbol is equipped with a refrigeration system independent of the structure, which provides improved flexibility and service.



## FSS • FAST SERVICE SYSTEM

- You can change the intended use of an appliance, a freezer into a chiller - and the other way around - even after years of installation.
- You can extend the life of a refrigeration cabinet by replacing its old refrigeration system with a new one.
- Maintenance and service are simple, quick and do not require specialised personnel.

FSS • Fast Service System

### NO-COMPROMISE QUALITY STEEL

**AISI 304**

AISI 304 18/10 is a high quality steel. Its stability guarantees good-looking and durable products, ensuring maximum hygiene and corrosion resistance over time.

**75 mm**

### INSULATION THICKNESS

The 75 mm thick insulation ensures lower heat loss, reduced work of the compressor, therefore lower energy consumption.

### INTELLIGENT DEFROST



Intelligent defrost changes according to the actual presence of frost. The system runs for the minimum time required.



### EVAPORATION SYSTEM

The automatic evaporation of condensing water is activated only in the presence of water produced as a result of a defrost cycle.

### CONSTANT TEMPERATURE



The fans stop when the door is opened to reduce temperature changes and consequently reduce the work of the compressor.



### ASPERA COMPRESSORS

Aspera compressors reduce energy consumption by 15% and acoustic impact by 5 dBA.

Focus

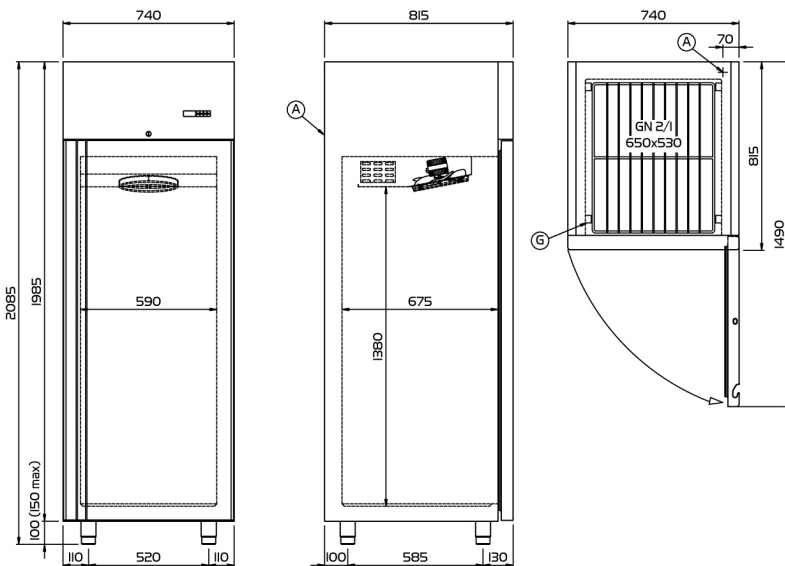

(A) POWER SUPPLY CABLE OUTLET

(G) RACKS PITCH



Technical drawing



Cold Line S.r.l. • Via E. Mattei, 38 • 35038 Torreglia • Padova - Italy • [www.coldline.it](http://www.coldline.it) • [info@coldline.it](mailto:info@coldline.it)

In order to constantly offer the best possible products, we reserve the right to make changes on technical specifications without incurring any obligation for equipment previously or subsequently sold.



• Trade mark:	Coldline
• Model:	A70/1NE
• Design:	Upright cabinet
• Energy efficiency class :	F
• Energy efficiency index :	91,0
• Net volume positive/negative:	435 -
• Climate class:	4 (30°C-55% r.h.)
• Energy consumption over 24 hours (E24h):	3,30
• Annual energy consumption in kWh:	1205
• Cooling gas:	R404a



# ENERG

енергия · ενεργεια

Y
IJA

IE
IA



## A70/1NE



ENERGIA · ЕНЕРГИЯ · ΕΝΕΡΓΕΙΑ  
ENERGIJA · ENERGY · ENERGIE  
ENERGI

# 1205

kWh/annum



435

L



-

L



4

30°C-55%

2015/1094-I

Energy label (UE 2015/1094)

Cold Line S.r.l. • Via E. Mattei, 38 • 35038 Torreglia • Padova - Italy • [www.coldline.it](http://www.coldline.it) • [info@coldline.it](mailto:info@coldline.it)

In order to constantly offer the best possible products, we reserve the right to make changes on technical specifications without incurring any obligation for equipment previously or subsequently sold.

